

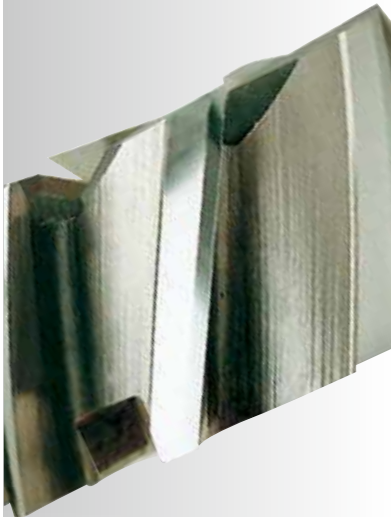

Leading Through Innovation



HSS

MILLING CUTTERS

HSS Fräser

- General Works. Available Dovetail, Woodruff Keyseat, T-slot, Side Milling Cutters and HSS (8% cobalt) Corner Rounding, Shell End Mills
- Allgemeine Arbeiten. Verfügbare Schwalbenschwanz, Passfedernut, T-Nut, Scheibenfräser, Scheibenfräser und HSS (8% Kobalt) Eckenverrundung, Walzenstirnfräser



PLAIN SHANK **ML012, ML022** SERIES
 FLAT SHANK **ML112, ML122** SERIES

HSS-E, DOVETAIL CUTTERS TYPE "A", "C", "E"

- HSS-E, WINKELFRÄSER FORM "A", "C", "E"
- Fraise HSS-E pour queue d'aronde Type "A", "C", "E"
- FRESE AD ANGOLO DIVERGENTE TIPO "A", "C", "E"

▶ Recommended for use in place of arbor and threaded hole type cutters to reduce set time and facilitate handling.

▶ Empfohlen zur Nutzung anstelle von Arbor and threaded hole type Cutters um Montierzeit zu verkürzen und Handhabung zu erleichtern.

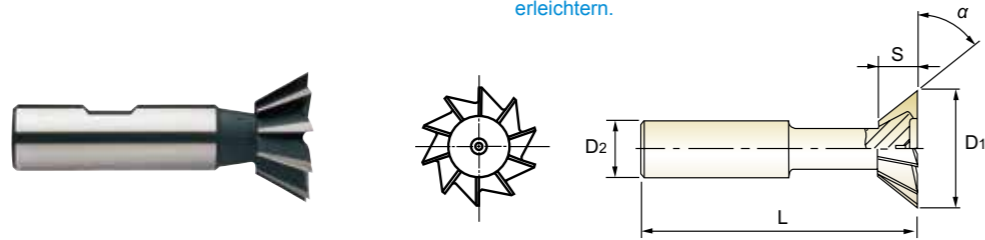

HSS-E DIN 1833 N 0° DIN 1835A DIN 1835B UNCOATED p.C726

Unit : mm

EDP No.		Cutter Diameter	Width of Face	Divergent Taper Angle	Shank Diameter	Overall Length	No. of Teeth
PLAIN	FLAT	D1(js16)	S(js14)	$\alpha(\pm 15^\circ)$	D2(h6)	L(js18)	Z
ML01201601	ML11201601	16.0	4	45°	12	60	6
ML01202001	ML11202001	20.0	5	45°	12	63	6
ML01202201	ML11202201	22.0	6	45°	12	67	6
ML01202501	ML11202501	25.0	6.3	45°	16	67	8
ML01202801	ML11202801	28.0	7.5	45°	16	67	8
ML01203201	ML11203201	32.0	8	45°	16	71	10
ML01203801	ML11203801	38.0	10	45°	16	80	12
ML02201601	ML12201601	16.0	6.3	60°	12	60	6
ML02202001	ML12202001	20.0	8	60°	12	63	6
ML02202201	ML12202201	22.0	9	60°	12	67	6
ML02202501	ML12202501	25.0	10	60°	16	67	8
ML02202801	ML12202801	28.0	11	60°	16	67	8
ML02203201	ML12203201	32.0	12.5	60°	16	71	10
ML02203801	ML12203801	38.0	16	60°	16	80	12
ML02204001	ML12204001	40.0	13	60°	25	85	12
ML02205001	ML12205001	50.0	16	60°	25	100	16

Tolerances according to DIN 7160 & 7161

	Nominal-Diameter in mm						
	over3 to6	over6 to10	over10 to18	over18 to30	over30 to50	over50 to80	over80 to120
Tolerance range in mm							
js16	± 0.375	± 0.45	± 0.55	± 0.65	± 0.80	± 0.95	± 1.10
js14	± 0.15	± 0.18	± 0.215	± 0.26	± 0.31	± 0.37	± 0.435
js18	± 0.90	± 1.10	± 1.35	± 1.65	± 1.95	± 2.30	± 2.70
Tolerance range in μm							
h6	0 -8	0 -9	0 -11	0 -13	0 -16	0 -19	0 -22

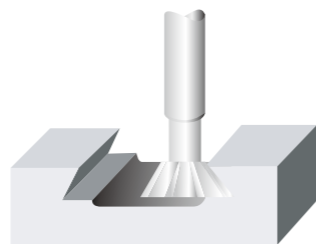

◎ : Excellent ○ : Good

ISO	P										M				K						
	Non-alloy steel					Low alloy steel					High alloyed steel, and tool steel		Stainless steel		Grey cast iron	Nodular cast iron		Malleable cast iron			
Material Description	1	2	3	4	5	6	7	8	9	10	11	12	13	14	15	16	17	18	19	20	
VDI 3323	1	2	3	4	5	6	7	8	9	10	11	12	13	14	15	16	17	18	19	20	
HRc	13	25	28	32	38	42	48	52	58	62	68	72	78	82	88	92	98	102	108	112	
HB	125	190	250	270	300	350	380	420	480	520	580	620	680	720	780	820	880	920	980	1020	
Recommended	◎	◎	◎	◎	◎	◎	◎	◎	◎	◎	◎	◎	◎	◎	◎	◎	◎	◎	◎	◎	◎



PLAIN SHANK **ML032, ML042** SERIES
 FLAT SHANK **ML132, ML142** SERIES

HSS-E, DOVETAIL CUTTERS TYPE "B", "D", "F"

- HSS-E, WINKELFRÄSER FORM "B", "D", "F"
- Fraise HSS-E pour queue d'aronde Type "B", "D", "F"
- FRESE AD ANGOLO CONVERGENTE TIPO "B", "D", "F"

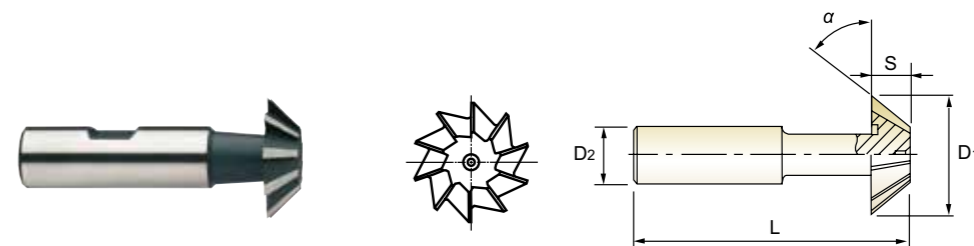

HSS-E DIN 1833 N 0° DIN 1835A DIN 1835B UNCOATED p.C727

Unit : mm

EDP No.		Cutter Diameter	Width of Face	Divergent Taper Angle	Shank Diameter	Overall Length	No. of Teeth
PLAIN	FLAT	D1(js16)	S(js14)	$\alpha(\pm 15^\circ)$	D2(h6)	L(js18)	Z
ML03201601	ML13201601	16.0	4	45°	12	60	6
ML03202001	ML13202001	20.0	5	45°	12	63	6
ML03202201	ML13202201	22.0	6	45°	12	67	6
ML03202501	ML13202501	25.0	6.3	45°	16	67	8
ML03202801	ML13202801	28.0	7.5	45°	16	67	8
ML03203201	ML13203201	32.0	8	45°	16	71	10
ML03203801	ML13203801	38.0	10	45°	16	80	12
ML04201601	ML14201601	16.0	6.3	60°	12	60	6
ML04202001	ML14202001	20.0	8	60°	12	63	6
ML04202201	ML14202201	22.0	9	60°	12	67	6
ML04202501	ML14202501	25.0	10	60°	16	67	8
ML04202801	ML14202801	28.0	11	60°	16	67	8
ML04203201	ML14203201	32.0	12.5	60°	16	71	10
ML04203801	ML14203801	38.0	16	60°	16	80	12

Tolerances according to DIN 7160 & 7161

	Nominal-Diameter in mm						
	over3 to6	over6 to10	over10 to18	over18 to30	over30 to50	over50 to80	over80 to120
Tolerance range in mm							
js16	± 0.375	± 0.45	± 0.55	± 0.65	± 0.80	± 0.95	± 1.10
js14	± 0.15	± 0.18	± 0.215	± 0.26	± 0.31	± 0.37	± 0.435
js18	± 0.90	± 1.10	± 1.35	± 1.65	± 1.95	± 2.30	± 2.70
Tolerance range in μm							
h6	0 -8	0 -9	0 -11	0 -13	0 -16	0 -19	0 -22

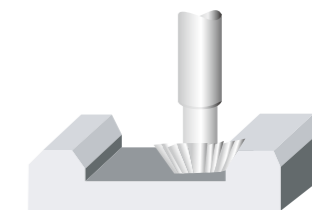

◎ : Excellent ○ : Good

ISO	P										M				K						
	Non-alloy steel					Low alloy steel					High alloyed steel, and tool steel		Stainless steel		Grey cast iron	Nodular cast iron		Malleable cast iron			
Material Description	1	2	3	4	5	6	7	8	9	10	11	12	13	14	15	16	17	18	19	20	
VDI 3323	1	2	3	4	5	6	7	8	9	10	11	12	13	14	15	16	17	18	19	20	
HRc	13	25	28	32	38	42	48	52	58	62	68	72	78	82	88	92	98	102	108	112	
HB	125	190	250	270	300	350	380	420	480	520	580	620	680	720	780	820	880	920	980	1020	
Recommended	◎	◎	◎	◎	◎	◎	◎	◎	◎	◎	◎	◎	◎	◎	◎	◎	◎	◎	◎	◎	◎



PLAIN SHANK **ML062** SERIES

FLAT SHANK **ML162** SERIES

HSS-E, WOODRUFF KEYSEAT CUTTERS TYPE "B", "D", "F"

- HSS-E, SCHLITZFRÄSER FORM "B", "D", "F"
- Fraise HSS-E WOODRUFF Type "B", "D", "F"
- FRESE PER CHIAVETTE WOODRUFF TIPO "B", "D", "F"

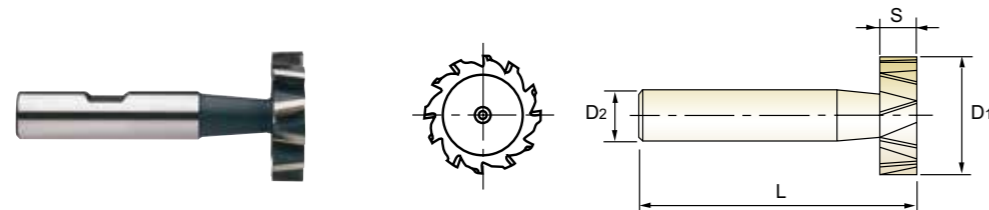

Unit : mm

EDP No.		Cutter Diameter	Width of Face	Shank Diameter	Overall Length	No. of Teeth
PLAIN	FLAT	D1(h11)	S(e8)	D2(h6)	L(js18)	Z
ML06210E01	ML16210E01	10.5	2	6	50	8
ML06210E02	ML16210E02	10.5	2.5	6	50	8
ML06210E03	ML16210E03	10.5	3	6	50	8
ML06213E01	ML16213E01	13.5	2	10	56	8
ML06213E02	ML16213E02	13.5	2.5	10	56	8
ML06213E03	ML16213E03	13.5	3	10	56	8
ML06213E04	ML16213E04	13.5	4	10	56	8
ML06216E01	ML16216E01	16.5	2.5	10	56	8
ML06216E02	ML16216E02	16.5	3	10	56	8
ML06216E03	ML16216E03	16.5	4	10	56	8
ML06216E04	ML16216E04	16.5	5	10	56	8
ML06219E01	ML16219E01	19.5	3	10	56	8
ML06219E02	ML16219E02	19.5	4	10	63	8
ML06219E03	ML16219E03	19.5	5	10	63	8
ML06219E04	ML16219E04	19.5	6	10	63	8
ML06222E01	ML16222E01	22.5	4	10	63	10
ML06222E02	ML16222E02	22.5	5	10	63	10
ML06222E03	ML16222E03	22.5	6	10	63	10
ML06222E04	ML16222E04	22.5	8	10	63	10
ML06225E01	ML16225E01	25.5	5	10	63	10

Tolerances according to DIN 7160 & 7161

	Nominal-Diameter in mm					
	from 1 to 3	over 3 to 6	over 6 to 10	over 10 to 18	over 18 to 30	over 30 to 80
js18	± 0.90	± 1.10	± 1.35	± 1.65	± 1.95	± 2.30
h11	0	0	0	0	0	0
e8	-60	-75	-90	-110	-130	-160
h6	-6	-8	-9	-11	-13	-19

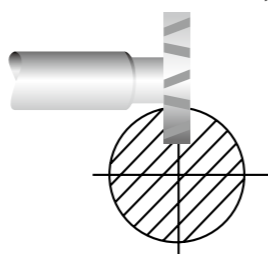

◎ : Excellent ○ : Good

ISO	P										M				K						
	Non-alloy steel					Low alloy steel					High alloyed steel, and tool steel				Stainless steel		Grey cast iron	Nodular cast iron		Malleable cast iron	
VDI 3323	1	2	3	4	5	6	7	8	9	10	11	12	13	14	15	16	17	18	19	20	
HRc	13	25	28	32	35	38	40	42	45	48	50	52	55	58	60	62	65	68	70	72	
HB	125	190	250	270	300	180	275	300	350	200	325	200	240	180	180	260	160	250	130	230	
Recommended	◎	◎	◎	◎	◎	◎	◎	◎	◎	◎	◎	◎	◎	◎	◎	◎	◎	◎	◎	◎	◎



PLAIN SHANK **ML062** SERIES

FLAT SHANK **ML162** SERIES

HSS-E, WOODRUFF KEYSEAT CUTTERS TYPE "B", "D", "F"

- HSS-E, SCHLITZFRÄSER FORM "B", "D", "F"
- Fraise HSS-E WOODRUFF Type "B", "D", "F"
- FRESE PER CHIAVETTE WOODRUFF TIPO "B", "D", "F"

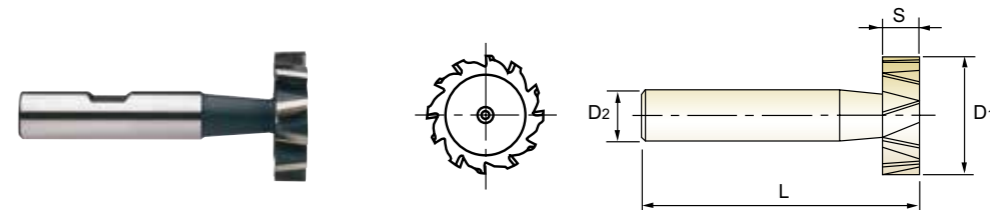

Unit : mm

EDP No.		Cutter Diameter	Width of Face	Shank Diameter	Overall Length	No. of Teeth
PLAIN	FLAT	D1(h11)	S(e8)	D2(h6)	L(js18)	Z
ML06225E02	ML16225E02	25.5	6	10	63	10
ML06225E03	ML16225E03	25.5	7	10	63	10
ML06225E04	ML16225E04	25.5	8	10	63	10
ML06228E01	ML16228E01	28.5	5	10	63	10
ML06228E02	ML16228E02	28.5	6	10	63	10
ML06228E03	ML16228E03	28.5	7	10	63	10
ML06228E04	ML16228E04	28.5	8	10	63	10
ML06228E05	ML16228E05	28.5	10	12	71	10
ML06232E01	ML16232E01	32.5	5	12	71	12
ML06232E02	ML16232E02	32.5	6	12	71	12
ML06232E03	ML16232E03	32.5	7	12	71	12
ML06232E04	ML16232E04	32.5	8	12	71	12
ML06232E05	ML16232E05	32.5	10	12	71	12
ML06238E01	ML16238E01	38.5	7	12	71	12
ML06238E02	ML16238E02	38.5	8	12	71	12
ML06238E03	ML16238E03	38.5	9	12	71	12
ML06238E04	ML16238E04	38.5	10	12	71	12
ML06245E01	ML16245E01	45.5	10	12	71	14

Tolerances according to DIN 7160 & 7161

	Nominal-Diameter in mm					
	from 1 to 3	over 3 to 6	over 6 to 10	over 10 to 18	over 18 to 30	over 30 to 80
js18	± 0.90	± 1.10	± 1.35	± 1.65	± 1.95	± 2.30
h11	0	0	0	0	0	0
e8	-60	-75	-90	-110	-130	-160
h6	-6	-8	-9	-11	-13	-19

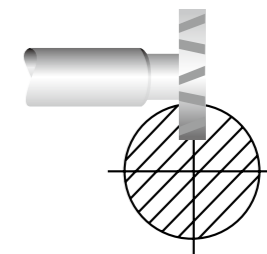

◎ : Excellent ○ : Good

ISO	P										M				K						
	Non-alloy steel					Low alloy steel					High alloyed steel, and tool steel				Stainless steel		Grey cast iron	Nodular cast iron		Malleable cast iron	
VDI 3323	1	2	3	4	5	6	7	8	9	10	11	12	13	14	15	16	17	18	19	20	
HRc	13	25	28	32	35	38	40	42	45	48	50	52	55	58	60	62	65	68	70	72	
HB	125	190	250	270	300	180	275	300	350	200	325	200	240	180	180	260	160	250	130	230	
Recommended	◎	◎	◎	◎	◎	◎	◎	◎	◎	◎	◎	◎	◎	◎	◎	◎	◎	◎	◎	◎	◎



PLAIN SHANK **ML072** SERIES

FLAT SHANK **ML172** SERIES

HSS-E, T-SLOT CUTTERS TYPE "AA", "AB", "AD"

- HSS-E, SCHAFERFRÄSER FÜR T-NUTEN FORM "AA", "AB", "AD"
- Fraise HSS-E pour rainure en "T" Type "AA", "AB", "AD"
- FRESE PER SCANALATURE A T - DENTI ALTERNATI

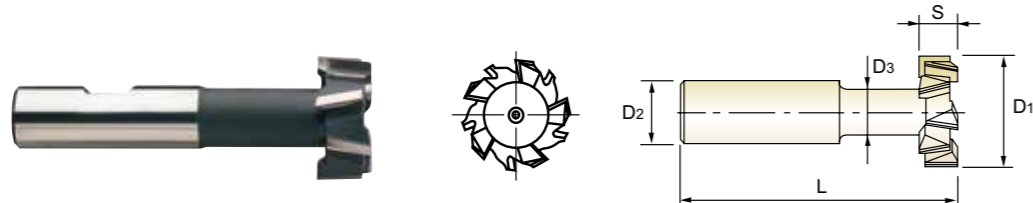

HSS-E DIN 851 N 10° DIN 1835A DIN 1835B UNCOATED p.C729

Unit : mm

EDP No.		Cutter Diameter	Width of Face	Shank Diameter	Neck Diameter	Overall Length	No. of Teeth
PLAIN	FLAT	D ₁ (d11)	S(d11)	D ₂ (h6)	D ₃ (h12)	L(js18)	Z
ML07212E01	ML17212E01	12.5	6	10	5	57	6
ML07201601	ML17201601	16.0	8	10	6.5	62	6
ML07201801	ML17201801	18.0	8	12	8	70	6
ML07201901	ML17201901	19.0	9	12	8	71	6
ML07202101	ML17202101	21.0	9	12	10	74	6
ML07202201	ML17202201	22.0	10	12	10	75	6
ML07202501	ML17202501	25.0	11	16	12	82	6
ML07202801	ML17202801	28.0	12	16	13	83	6
ML07203201	ML17203201	32.0	14	16	15	90	8
ML07203601	ML17203601	36.0	16	25	17	103	8
ML07204001	ML17204001	40.0	18	25	19	108	8

Tolerances according to DIN 7160 & 7161

	Nominal-Diameter in mm						
	over3 to 6	over6 to 10	over10 to 18	over18 to 30	over30 to 50	over50 to 80	over80 to 120
Tolerance range in mm							
h12	0 -0.12	0 -0.15	0 -0.18	0 -0.21	0 -0.25	0 -0.30	0 -0.35
js18	± 0.90	± 1.10	± 1.35	± 1.65	± 1.95	± 2.30	± 2.70
Tolerance range in μm							
d11	-30 -105	-40 -130	-50 -160	-65 -195	-80 -240	-100 -290	-120 -340
h6	0 -8	0 -9	0 -11	0 -13	0 -16	0 -19	0 -22

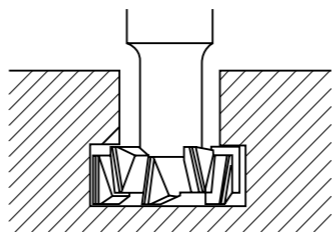

◎ : Excellent ○ : Good

ISO	P										M				K					
	Non-alloy steel					Low alloy steel					High alloyed steel, and tool steel		Stainless steel		Grey cast iron		Nodular cast iron		Malleable cast iron	
Material Description	1	2	3	4	5	6	7	8	9	10	11	12	13	14	15	16	17	18	19	20
VDI 3323	1	2	3	4	5	6	7	8	9	10	11	12	13	14	15	16	17	18	19	20
HRc	13	25	28	32	38	40	45	50	55	60	65	70	75	80	85	90	95	100	105	110
HB	125	190	250	270	300	180	275	300	350	200	325	200	240	180	180	260	160	250	130	230
Recommended	◎	◎	◎	◎	◎	◎	◎	◎	◎	◎	◎	◎	◎	◎	◎	◎	◎	◎	◎	◎



STRAIGHT TEETH **ML092** SERIES

HSS-E, SIDE AND FACE MILLING CUTTERS with STRAIGHT TEETH

- HSS-E, SCHEIBENFRÄSER mit GERADEVERZAHNT
- Fraise HSS-E 3 Tailles, denture droite
- FRESE A DISCO A TRE TAGLI - DENTI DRITTI

▶ The tools are used for general purpose side and straddle milling where deep cut is not required.

▶ Diese Werkzeuge werden bei allgemeinen Seiten-und Breitfräsen eingesetzt, wo Tiefschnitte nicht vorkommen.

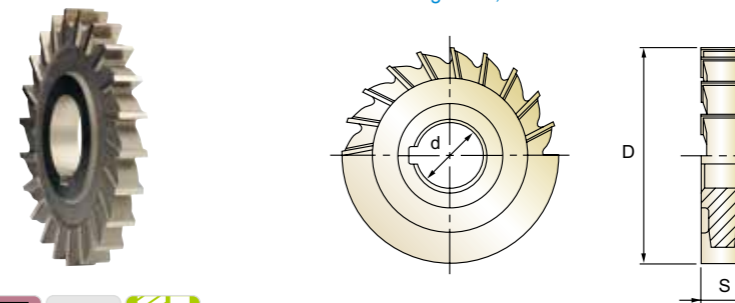

HSS-E DIN 885-B H UNCOATED p.C730

Unit : mm

EDP No.	Cutter Diameter	Width of Face	Internal Diameter	No. of Teeth
	D ₁ (js14)	S(k11)	d(H7)	Z
ML09205001	50.0	4	16	18
ML09205002	50.0	5	16	18
ML09205003	50.0	6	16	18
ML09205004	50.0	8	16	16
ML09205005	50.0	10	16	16
ML09206301	63.0	5	22	22
ML09206302	63.0	6	22	22
ML09206303	63.0	8	22	20
ML09206304	63.0	10	22	20
ML09206305	63.0	12	22	20
ML09208001	80.0	6	22	24
ML09208002	80.0	8	22	24
ML09208003	80.0	10	22	24
ML09208004	80.0	12	22	20
ML09208005	80.0	6	27	24
ML09208006	80.0	8	27	24
ML09208007	80.0	10	27	24
ML09208008	80.0	12	27	20
ML09210001	100.0	6	27	26
ML09210002	100.0	8	27	26

Tolerances according to DIN 7160 & 7161

	Nominal-Diameter in mm						
	over3 to 6	over6 to 10	over10 to 18	over18 to 30	over30 to 50	over50 to 80	over80 to 120
Tolerance range in mm							
js14	± 0.15	± 0.18	± 0.215	± 0.26	± 0.31	± 0.37	± 0.435
Tolerance range in μm							
k11	+75 0	+90 0	+110 0	+130 0	+160 0	+190 0	+220 0
H7	+12 0	+15 0	+18 0	+21 0	+25 0	+30 0	+35 0

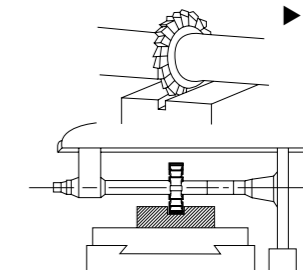

◎ : Excellent ○ : Good

ISO	P										M				K					
	Non-alloy steel					Low alloy steel					High alloyed steel, and tool steel		Stainless steel		Grey cast iron		Nodular cast iron		Malleable cast iron	
Material Description	1	2	3	4	5	6	7	8	9	10	11	12	13	14	15	16	17	18	19	20
VDI 3323	1	2	3	4	5	6	7	8	9	10	11	12	13	14	15	16	17	18	19	20
HRc	13	25	28	32	38	40	45	50	55	60	65	70	75	80	85	90	95	100	105	110
HB	125	190	250	270	300	180	275	300	350	200	325	200	240	180	180	260	160	250	130	230
Recommended	◎	◎	◎	◎	◎	◎	◎	◎	◎	◎	◎	◎	◎	◎	◎	◎	◎	◎	◎	◎

HSS-E, SIDE AND FACE MILLING CUTTERS with STRAIGHT TEETH

- HSS-E, SCHEIBENFRÄSER mit GERADEVERZAHNT
- Fraise HSS-E 3 Tailles, denture droite
- FRESE A DISCO A TRE TAGLI - DENTI DRITTI

▶ The tools are used for general purpose side and straddle milling where deep cut is not required.

▶ Diese Werkzeuge werden bei allgemeinen Seiten-und Breitfräsen eingesetzt, wo Tiefschnitte nicht vorkommen.

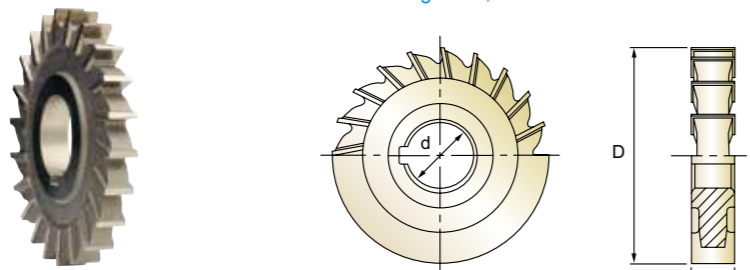

Unit : mm

EDP No.	Cutter Diameter	Width of Face	Internal Diameter	No. of Teeth
	D(js14)	S(k11)	d(H7)	Z
ML09210003	100.0	10	27	22
ML09210004	100.0	6	32	26
ML09210005	100.0	8	32	26
ML09210006	100.0	10	32	22
ML09210007	100.0	12	32	22
ML09212501	125.0	8	32	30
ML09212502	125.0	10	32	30
ML09212503	125.0	12	32	24

Tolerances according to DIN 7160 & 7161

	Nominal-Diameter in mm							
	over3to6	over6to10	over10to18	over18to30	over30to50	over50to80	over80to120	over120to180
Tolerance range in mm								
js14	± 0.15	± 0.18	± 0.215	± 0.26	± 0.31	± 0.37	± 0.435	± 0.50
Tolerance range in µm								
k11	+75 0	+90 0	+110 0	+130 0	+160 0	+190 0	+220 0	+250 0
H7	+12 0	+15 0	+18 0	+21 0	+25 0	+30 0	+35 0	+40 0

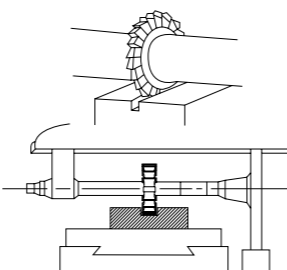

◎ : Excellent ○ : Good

ISO	P										M				K					
	Non-alloy steel					Low alloy steel					High alloyed steel, and tool steel		Stainless steel		Grey cast iron	Nodular cast iron		Malleable cast iron		
Material Description	1	2	3	4	5	6	7	8	9	10	11	12	13	14	15	16	17	18	19	20
VDI 3323	1	2	3	4	5	6	7	8	9	10	11	12	13	14	15	16	17	18	19	20
HRc	13	25	28	32	38	42	48	52	58	62	68	72	78	82	88	92	98	102	108	112
HB	125	190	250	270	300	180	275	300	350	200	325	200	240	180	180	260	160	250	130	230
Recommended	◎	◎	◎	◎	◎	◎	◎	◎	◎	◎	◎	◎	◎	◎	◎	◎	◎	◎	◎	◎

HSS-E, SIDE AND FACE MILLING CUTTERS with STAGGERED TEETH

- HSS-E, SCHEIBENFRÄSER mit KREUZVERZAHNT
- Fraise HSS-E 3 Tailles, denture alternée
- FRESE A DISCO A TRE TAGLI - DENTI ALTERNATI

▶ The type of cutter is recommended for slotting operations. The alternate spiral effectively counteracts all tendency to chatter.

▶ Dieser Typ ist zum Schlitzfräsen geeignet. Das alternierende Spiral wirkt allen Schnatterbewegungen entgegen.

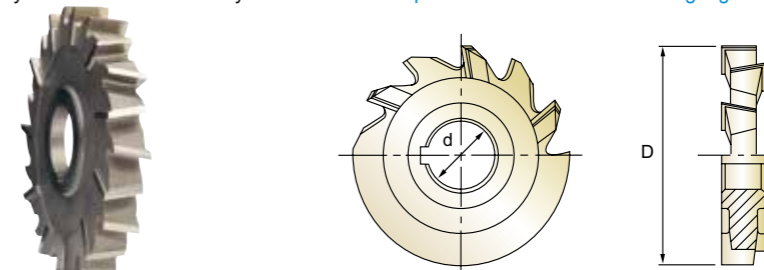

Unit : mm

EDP No.	Cutter Diameter	Width of Face	Internal Diameter	No. of Teeth
	D(js14)	S(k11)	d(H7)	Z
ML10205001	50.0	3	16	14
ML10205002	50.0	4	16	14
ML10205003	50.0	5	16	14
ML10205004	50.0	6	16	14
ML10205005	50.0	7	16	14
ML10205006	50.0	8	16	14
ML10205007	50.0	9	16	14
ML10205008	50.0	10	16	14
ML10206301	63.0	3	22	16
ML10206302	63.0	4	22	16
ML10206303	63.0	5	22	16
ML10206304	63.0	6	22	16
ML10206305	63.0	7	22	16
ML10206306	63.0	8	22	16
ML10206307	63.0	9	22	16
ML10206308	63.0	10	22	16
ML10206309	63.0	12	22	16
ML10206310	63.0	14	22	16
ML10206311	63.0	16	22	16
ML10206312	63.0	18	22	16

Tolerances according to DIN 7160 & 7161

	Nominal-Diameter in mm								
	over3to6	over6to10	over10to18	over18to30	over30to50	over50to80	over80to120	over120to180	over180to250
Tolerance range in mm									
js14	± 0.15	± 0.18	± 0.215	± 0.26	± 0.31	± 0.37	± 0.435	± 0.50	± 0.575
Tolerance range in µm									
k11	+75 0	+90 0	+110 0	+130 0	+160 0	+190 0	+220 0	+250 0	+290 0
H7	+12 0	+15 0	+18 0	+21 0	+25 0	+30 0	+35 0	+40 0	+46 0

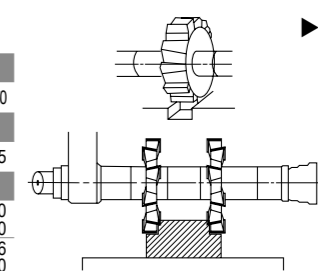

◎ : Excellent ○ : Good

ISO	P										M				K					
	Non-alloy steel					Low alloy steel					High alloyed steel, and tool steel		Stainless steel		Grey cast iron	Nodular cast iron		Malleable cast iron		
Material Description	1	2	3	4	5	6	7	8	9	10	11	12	13	14	15	16	17	18	19	20
VDI 3323	1	2	3	4	5	6	7	8	9	10	11	12	13	14	15	16	17	18	19	20
HRc	13	25	28	32	38	42	48	52	58	62	68	72	78	82	88	92	98	102	108	112
HB	125	190	250	270	300	180	275	300	350	200	325	200	240	180	180	260	160	250	130	230
Recommended	◎	◎	◎	◎	◎	◎	◎	◎	◎	◎	◎	◎	◎	◎	◎	◎	◎	◎	◎	◎

HSS-E, SIDE AND FACE MILLING CUTTERS with STAGGERED TEETH

- HSS-E, SCHEIBENFRÄSER mit KREUZVERZAHNT
- Fraise HSS-E 3 Tailles, denture alternée
- FRESE A DISCO A TRE TAGLI - DENTI ALTERNATI

▶ The type of cutter is recommended for slotting operations. The alternate spiral effectively counteracts all tendency to chatter.
 ▶ Dieser Typ ist zum Schlitzfräsen geeignet. Das alternierende Spiral wirkt allen Schnatterbewegungen entgegen.

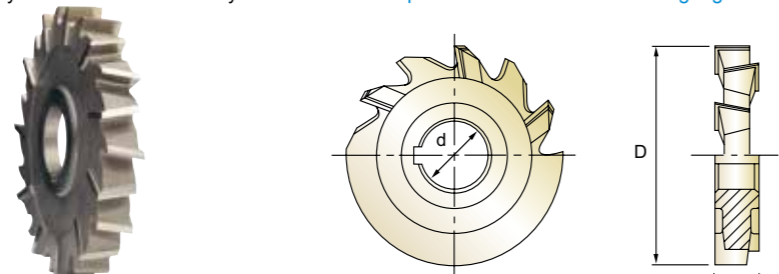

Unit : mm

EDP No.	Cutter Diameter	Width of Face	Internal Diameter	No. of Teeth
	D(js14)	S(k11)	d(H7)	Z
ML10208001	80.0	3	22	18
ML10208002	80.0	4	22	18
ML10208003	80.0	5	22	18
ML10208004	80.0	6	22	18
ML10208005	80.0	7	22	18
ML10208006	80.0	8	22	18
ML10208007	80.0	9	22	18
ML10208008	80.0	10	22	18
ML10208009	80.0	12	22	18
ML10208010	80.0	14	22	18
ML10208011	80.0	16	22	18
ML10208012	80.0	18	22	18
ML10208013	80.0	20	22	18
ML10208014	80.0	4	27	18
ML10208015	80.0	5	27	18
ML10208016	80.0	6	27	18
ML10208017	80.0	7	27	18
ML10208018	80.0	8	27	18
ML10208019	80.0	9	27	18
ML10208020	80.0	10	27	18

Tolerances according to DIN 7160 & 7161

	Nominal-Diameter in mm								
	over 3 to 6	over 6 to 10	over 10 to 18	over 18 to 30	over 30 to 50	over 50 to 80	over 80 to 120	over 120 to 180	over 180 to 250
Tolerance range in mm									
js14	± 0.15	± 0.18	± 0.215	± 0.26	± 0.31	± 0.37	± 0.435	± 0.50	± 0.575
Tolerance range in μm									
k11	+75 0	+90 0	+110 0	+130 0	+160 0	+190 0	+220 0	+250 0	+290 0
H7	+12 0	+15 0	+18 0	+21 0	+25 0	+30 0	+35 0	+40 0	+46 0

◎ : Excellent ○ : Good

ISO	P														M				K		
	Non-alloy steel					Low alloy steel					High alloyed steel, and tool steel				Stainless steel		Grey cast iron	Nodular cast iron		Malleable cast iron	
Material Description	1	2	3	4	5	6	7	8	9	10	11	12	13	14	15	16	17	18	19	20	
VDI 3323	1	2	3	4	5	6	7	8	9	10	11	12	13	14	15	16	17	18	19	20	
HRc	13	25	28	32	32	32	32	32	32	32	32	32	32	32	32	32	32	32	32	32	
HB	125	190	250	270	300	180	275	300	350	200	325	200	240	180	180	260	160	250	130	230	
Recommended	◎	◎	◎	◎	◎	◎	◎	◎	◎	◎	◎	◎	◎	◎	◎	◎	◎	◎	◎	◎	

HSS-E, SIDE AND FACE MILLING CUTTERS with STAGGERED TEETH

- HSS-E, SCHEIBENFRÄSER mit KREUZVERZAHNT
- Fraise HSS-E 3 Tailles, denture alternée
- FRESE A DISCO A TRE TAGLI - DENTI ALTERNATI

▶ The type of cutter is recommended for slotting operations. The alternate spiral effectively counteracts all tendency to chatter.
 ▶ Dieser Typ ist zum Schlitzfräsen geeignet. Das alternierende Spiral wirkt allen Schnatterbewegungen entgegen.

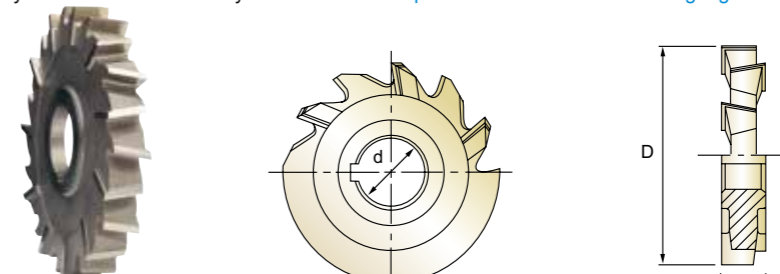

Unit : mm

EDP No.	Cutter Diameter	Width of Face	Internal Diameter	No. of Teeth
	D(js14)	S(k11)	d(H7)	Z
ML10208021	80.0	12	27	18
ML10208022	80.0	14	27	18
ML10208023	80.0	16	27	18
ML10208024	80.0	18	27	18
ML10208025	80.0	20	27	18
ML10210001	100.0	3	27	20
ML10210002	100.0	4	27	20
ML10210003	100.0	5	27	20
ML10210004	100.0	6	27	20
ML10210005	100.0	7	27	20
ML10210006	100.0	8	27	20
ML10210007	100.0	9	27	20
ML10210008	100.0	10	27	20
ML10210009	100.0	12	27	20
ML10210010	100.0	14	27	20
ML10210011	100.0	15	27	20
ML10210012	100.0	16	27	20
ML10210013	100.0	18	27	20
ML10210014	100.0	20	27	20
ML10210015	100.0	4	32	20

Tolerances according to DIN 7160 & 7161

	Nominal-Diameter in mm								
	over 3 to 6	over 6 to 10	over 10 to 18	over 18 to 30	over 30 to 50	over 50 to 80	over 80 to 120	over 120 to 180	over 180 to 250
Tolerance range in mm									
js14	± 0.15	± 0.18	± 0.215	± 0.26	± 0.31	± 0.37	± 0.435	± 0.50	± 0.575
Tolerance range in μm									
k11	+75 0	+90 0	+110 0	+130 0	+160 0	+190 0	+220 0	+250 0	+290 0
H7	+12 0	+15 0	+18 0	+21 0	+25 0	+30 0	+35 0	+40 0	+46 0

◎ : Excellent ○ : Good

ISO	P														M				K		
	Non-alloy steel					Low alloy steel					High alloyed steel, and tool steel				Stainless steel		Grey cast iron	Nodular cast iron		Malleable cast iron	
Material Description	1	2	3	4	5	6	7	8	9	10	11	12	13	14	15	16	17	18	19	20	
VDI 3323	1	2	3	4	5	6	7	8	9	10	11	12	13	14	15	16	17	18	19	20	
HRc	13	25	28	32	32	32	32	32	32	32	32	32	32	32	32	32	32	32	32	32	
HB	125	190	250	270	300	180	275	300	350	200	325	200	240	180	180	260	160	250	130	230	
Recommended	◎	◎	◎	◎	◎	◎	◎	◎	◎	◎	◎	◎	◎	◎	◎	◎	◎	◎	◎	◎	

HSS-E, SIDE AND FACE MILLING CUTTERS with STAGGERED TEETH

- HSS-E, SCHEIBENFRÄSER mit KREUZVERZAHNT
- Fraise HSS-E 3 Tailles, denture alternée
- FRESE A DISCO A TRE TAGLI - DENTI ALTERNATI

▶ The type of cutter is recommended for slotting operations. The alternate spiral effectively counteracts all tendency to chatter.
 ▶ Dieser Typ ist zum Schlitzfräsen geeignet. Das alternierende Spiral wirkt allen Schnatterbewegungen entgegen.

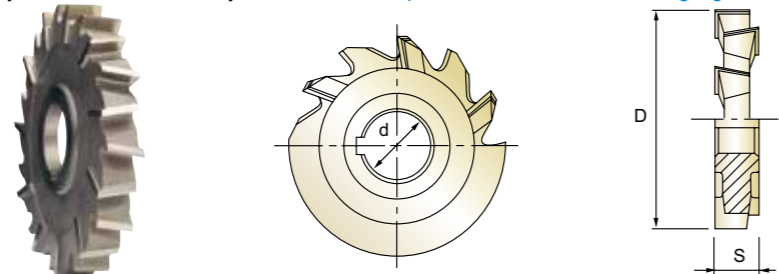

Unit : mm

EDP No.	Cutter Diameter	Width of Face	Internal Diameter	No. of Teeth
	D(js14)	S(k11)	d(H7)	Z
ML10210016	100.0	5	32	20
ML10210017	100.0	6	32	20
ML10210018	100.0	7	32	20
ML10210019	100.0	8	32	20
ML10210020	100.0	9	32	20
ML10210021	100.0	10	32	20
ML10210022	100.0	12	32	20
ML10210023	100.0	14	32	20
ML10210024	100.0	15	32	20
ML10210025	100.0	16	32	20
ML10210026	100.0	18	32	20
ML10210027	100.0	20	32	20
ML10212501	125.0	5	32	22
ML10212502	125.0	6	32	22
ML10212503	125.0	8	32	22
ML10212504	125.0	10	32	22
ML10212505	125.0	12	32	22
ML10212506	125.0	14	32	22
ML10212507	125.0	16	32	22
ML10212508	125.0	18	32	22

Tolerances according to DIN 7160 & 7161

	Nominal-Diameter in mm								
	over3to6	over6to10	over10to18	over18to30	over30to50	over50to80	over80to120	over120to180	over180to250
Tolerance range in mm									
js14	±0.15	±0.18	±0.215	±0.26	±0.31	±0.37	±0.435	±0.50	±0.575
Tolerance range in μm									
k11	+75 0	+90 0	+110 0	+130 0	+160 0	+190 0	+220 0	+250 0	+290 0
H7	+12 0	+15 0	+18 0	+21 0	+25 0	+30 0	+35 0	+40 0	+46 0

◎ : Excellent ○ : Good

ISO	P														M				K																						
	Non-alloy steel					Low alloy steel					High alloyed steel, and tool steel				Stainless steel		Grey cast iron	Nodular cast iron		Malleable cast iron																					
Material Description	1	2	3	4	5	6	7	8	9	10	11	12	13	14	15	16	17	18	19	20	21	22	23	24	25	26	27	28	29	30	31	32	33	34	35	36	37	38	39	40	41
VDI 3323	1	2	3	4	5	6	7	8	9	10	11	12	13	14	15	16	17	18	19	20	21	22	23	24	25	26	27	28	29	30	31	32	33	34	35	36	37	38	39	40	41
HRc	13	25	28	32	38	42	48	52	58	62	68	72	78	82	88	92	98	102	108	112	118	122	128	132	138	142	148	152	158	162	168	172	178	182	188	192	198	202	208	212	
HB	125	190	250	270	300	350	380	420	450	500	550	600	650	700	750	800	850	900	950	1000	1050	1100	1150	1200	1250	1300	1350	1400	1450	1500	1550	1600	1650	1700	1750	1800	1850	1900	1950	2000	
Recommended	◎	◎	◎	◎	◎	◎	◎	◎	◎	◎	◎	◎	◎	◎	◎	◎	◎	◎	◎	◎	◎	◎	◎	◎	◎	◎	◎	◎	◎	◎	◎	◎	◎	◎	◎	◎	◎	◎	◎	◎	◎

HSS-E, SIDE AND FACE MILLING CUTTERS with STAGGERED TEETH

- HSS-E, SCHEIBENFRÄSER mit KREUZVERZAHNT
- Fraise HSS-E 3 Tailles, denture alternée
- FRESE A DISCO A TRE TAGLI - DENTI ALTERNATI

▶ The type of cutter is recommended for slotting operations. The alternate spiral effectively counteracts all tendency to chatter.
 ▶ Dieser Typ ist zum Schlitzfräsen geeignet. Das alternierende Spiral wirkt allen Schnatterbewegungen entgegen.

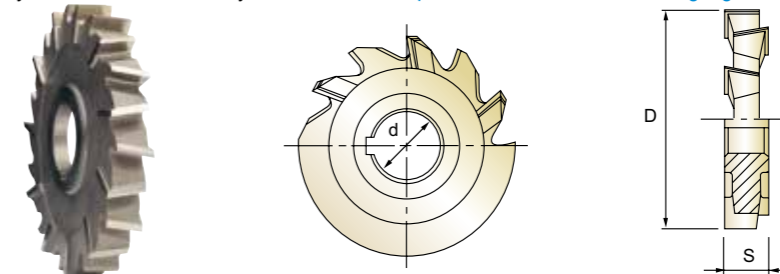

Unit : mm

EDP No.	Cutter Diameter	Width of Face	Internal Diameter	No. of Teeth
	D(js14)	S(k11)	d(H7)	Z
ML10212509	125.0	20	32	22
ML10216001	160.0	6	32	26
ML10216002	160.0	8	32	26
ML10216003	160.0	10	32	26
ML10216004	160.0	12	32	26
ML10216005	160.0	14	32	26
ML10216006	160.0	16	32	26
ML10216007	160.0	18	32	26
ML10216008	160.0	20	32	26
ML10216009	160.0	6	40	26
ML10216010	160.0	8	40	26
ML10216011	160.0	10	40	26
ML10216012	160.0	12	40	26
ML10216013	160.0	14	40	26
ML10216014	160.0	16	40	26
ML10216015	160.0	18	40	26
ML10216016	160.0	20	40	26
ML10220001	200.0	10	40	30
ML10220002	200.0	12	40	30
ML10220003	200.0	14	40	30

Tolerances according to DIN 7160 & 7161

	Nominal-Diameter in mm								
	over3to6	over6to10	over10to18	over18to30	over30to50	over50to80	over80to120	over120to180	over180to250
Tolerance range in mm									
js14	±0.15	±0.18	±0.215	±0.26	±0.31	±0.37	±0.435	±0.50	±0.575
Tolerance range in μm									
k11	+75 0	+90 0	+110 0	+130 0	+160 0	+190 0	+220 0	+250 0	+290 0
H7	+12 0	+15 0	+18 0	+21 0	+25 0	+30 0	+35 0	+40 0	+46 0

◎ : Excellent ○ : Good

ISO	P														M				K																							
	Non-alloy steel					Low alloy steel					High alloyed steel, and tool steel				Stainless steel		Grey cast iron	Nodular cast iron		Malleable cast iron																						
Material Description	1	2	3	4	5	6	7	8	9	10	11	12	13	14	15	16	17	18	19	20	21	22	23	24	25	26	27	28	29	30	31	32	33	34	35	36	37	38	39	40	41	
VDI 3323	1	2	3	4	5	6	7	8	9	10	11	12	13	14	15	16	17	18	19	20	21	22	23	24	25	26	27	28	29	30	31	32	33	34	35	36	37	38	39	40	41	
HRc	13	25	28	32	38	42	48	52	58	62	68	72	78	82	88	92	98	102	108	112	118	122	128	132	138	142	148	152	158	162	168	172	178	182	188	192	198	202	208	212		
HB	125	190	250	270	300	350	380	420	450	500	550	600	650	700	750	800	850	900	950	1000	1050	1100	1150	1200	1250	1300	1350	1400	1450	1500	1550	1600	1650	1700	1750	1800	1850	1900	1950	2000		
Recommended	◎	◎	◎	◎	◎	◎	◎	◎	◎	◎	◎	◎	◎	◎	◎	◎	◎	◎	◎	◎	◎	◎	◎	◎	◎	◎	◎	◎	◎	◎	◎	◎	◎	◎	◎	◎	◎	◎	◎	◎	◎	◎



STAGGERED TEETH **ML102** SERIES

HSS-E, SIDE AND FACE MILLING CUTTERS with STAGGERED TEETH

- HSS-E, SCHEIBENFRÄSER mit KREUZVERZAHNT
- Fraise HSS-E 3 Tailles, denture alternée
- FRESE A DISCO A TRE TAGLI - DENTI ALTERNATI

▶ The type of cutter is recommended for slotting operations. The alternate spiral effectively counteracts all tendency to chatter.
 ▶ Dieser Typ ist zum Schlitzfräsen geeignet. Das alternierende Spiral wirkt allen Schnatterbewegungen entgegen.

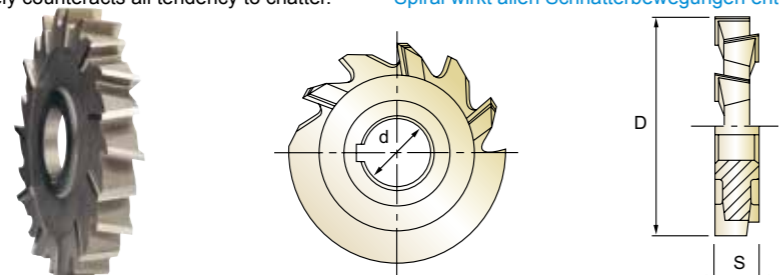

HSS-E DIN 885-A H UNCOATED p.C731

EDP No.	Cutter Diameter	Width of Face	Internal Diameter	No. of Teeth
	D(js14)	S(k11)	d(H7)	Z
ML10220004	200.0	16	40	30
ML10220005	200.0	18	40	30
ML10220006	200.0	20	40	30
ML10220007	200.0	22	40	30
ML10220008	200.0	25	40	30

Tolerances according to DIN 7160 & 7161

	Nominal-Diameter in mm								
	over 3 to 6	over 6 to 10	over 10 to 18	over 18 to 30	over 30 to 50	over 50 to 80	over 80 to 120	over 120 to 180	over 180 to 250
Tolerance range in mm									
js14	± 0.15	± 0.18	± 0.215	± 0.26	± 0.31	± 0.37	± 0.435	± 0.50	± 0.575
Tolerance range in μm									
k11	+75 0	+90 0	+110 0	+130 0	+160 0	+190 0	+220 0	+250 0	+290 0
H7	+12 0	+15 0	+18 0	+21 0	+25 0	+30 0	+35 0	+40 0	+46 0

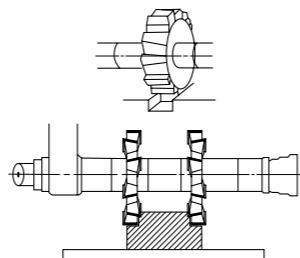

◎ : Excellent ○ : Good

ISO	P										M				K					
	Non-alloy steel					Low alloy steel					High alloyed steel, and tool steel				Stainless steel		Grey cast iron	Nodular cast iron		Malleable cast iron
Material Description	1	2	3	4	5	6	7	8	9	10	11	12	13	14	15	16	17	18	19	20
VDI 3323	1	2	3	4	5	6	7	8	9	10	11	12	13	14	15	16	17	18	19	20
HRc	13	25	28	32	38	42	48	52	58	62	68	72	78	82	88	92	98	102	108	112
HB	125	190	250	270	300	180	275	300	350	200	325	200	240	180	180	260	160	250	130	230
Recommended	◎	◎	◎	◎	◎	◎	◎	◎	◎	◎	◎	◎	◎	◎	◎	◎	◎	◎	◎	◎

ISO	N										S					H					
	Aluminum-wrought alloy		Aluminum-cast, alloyed			Copper and Copper Alloys (Bronze / Brass)			Non Metallic Materials		Heat Resistant Super Alloys					Titanium Alloys		Hardened steel	Chilled Cast Iron	Hardened Cast Iron	
Material Description	21	22	23	24	25	26	27	28	29	30	31	32	33	34	35	36	37	38	39	40	41
VDI 3323	21	22	23	24	25	26	27	28	29	30	31	32	33	34	35	36	37	38	39	40	41
HRc	21	22	23	24	25	26	27	28	29	30	31	32	33	34	35	36	37	38	39	40	41
HB	60	100	75	90	130	110	90	100			200	280	250	350	320	400 Rm	1050 Rm	550	630	400	550
Recommended	◎	◎	◎	◎	◎	◎	◎	◎	◎	◎	◎	◎	◎	◎	◎	◎	◎	◎	◎	◎	◎



E2675 SERIES

HSSCo8, MULTI FLUTE SHELL END MILL

- HSSCo8, MULTI SCHNEIDEN WALZENSTIRNFRÄSER
- Fraise HSSCo8, multi-dents trou lisse
- FRESA CILINDRICA FRONTALE, MULTI TAGLIENTE

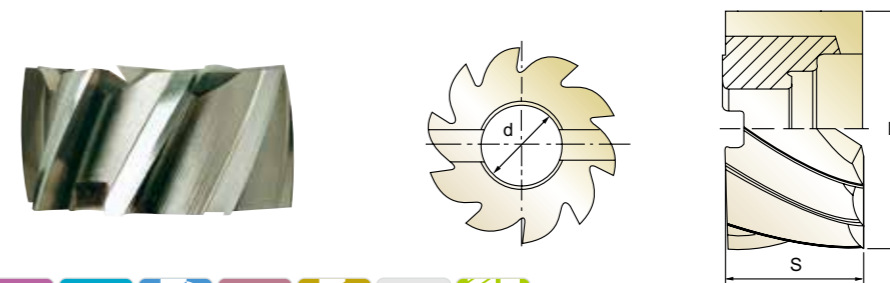

HSS Co8 DIN 841 N 6-10 30° UNCOATED p.C732

EDP No.	Mill Diameter	Width of Face	Internal Diameter	No. of Teeth
	D	S	d	Z
E2675300	30.0	30	● 13	6
E2675350	35.0	35	● 16	6
E2675400	40.0	20	● 16	8
E2675402	40.0	40	● 16	8
E2675500	50.0	25	22	8
E2675502	50.0	50	22	8
E2675600	60.0	30	27	8
E2675601	60.0	60	27	8
E2675750	75.0	35	27	10
E2675751	75.0	75	27	10
E2675900	90.0	35	27	10
E2675902	110.0	35	32	10

● Tolerance of Internal Diameter = +0.018 ~ 0
▶ TIN-COATING, TICN-COATING & TiAIN-COATING is available on your request.

HSS Co8 DIN 1880 N 8-14 30° UNCOATED p.C732

EDP No.	Mill Diameter	Width of Face	Internal Diameter	No. of Teeth
	D	S	d	Z
E2675401	40.0	32	● 16	8
E2675501	50.0	36	22	8
E2675630	63.0	40	27	8
E2675800	80.0	45	27	10
E2675901	100.0	50	32	10
E2675903	125.0	56	40	12
E2675904	160.0	63	50	14

● Tolerance of Internal Diameter = +0.018 ~ 0
▶ TIN-COATING, TICN-COATING & TiAIN-COATING is available on your request.

Mill Dia. Tolerance(mm)	Width of Face Tolerance(mm)	Internal Dia. Tolerance(mm)
+ 0.25 - 0.15	+ 0.5 - 0	+ 0.02 - 0

◎ : Excellent ○ : Good

ISO	P										M				K					
	Non-alloy steel					Low alloy steel					High alloyed steel, and tool steel				Stainless steel		Grey cast iron	Nodular cast iron		Malleable cast iron
Material Description	1	2	3	4	5	6	7	8	9	10	11	12	13	14	15	16	17	18	19	20
VDI 3323	1	2	3	4	5	6	7	8	9	10	11	12	13	14	15	16	17	18	19	20
HRc	13	25	28	32	38	42	48	52	58	62	68	72	78	82	88	92	98	102	108	112
HB	125	190	250	270	300	180	275	300	350	200	325	200	240	180	180	260	160	250	130	230
Recommended	◎	◎	◎	◎	◎	◎	◎	◎	◎	◎	◎	◎	◎	◎	◎	◎	◎	◎	◎	◎

ISO	N										S					H					
	Aluminum-wrought alloy		Aluminum-cast, alloyed			Copper and Copper Alloys (Bronze / Brass)			Non Metallic Materials		Heat Resistant Super Alloys					Titanium Alloys		Hardened steel	Chilled Cast Iron	Hardened Cast Iron	
Material Description	21	22	23	24	25	26	27	28	29	30	31	32	33	34	35	36	37	38	39	40	41
VDI 3323	21	22	23	24	25	26	27	28	29	30	31	32	33	34	35	36	37	38	39	40	41
HRc	21	22	23	24	25	26	27	28	29	30	31	32	33	34	35	36	37	38	39	40	41
HB	60	100	75	90	130	110	90	100			200	280	250	350	320	400 Rm	1050 Rm	550	630	400	550
Recommended	◎	◎	◎	◎	◎	◎	◎	◎	◎	◎	◎	◎	◎	◎	◎	◎	◎	◎	◎	◎	◎

HSSCo8, MULTI FLUTE SHELL END MILL for ALUMINIUM

- HSSCo8, MULTI SCHNEIDEN WALZENSTIRNFRÄSER für ALUMINIUM
- Fraise HSSCo8, multi-dents trou lisse pour aluminium
- FRESA CILINDRICA FRONTALE MULTI TAGLIENTE, PER ALLUMINIO

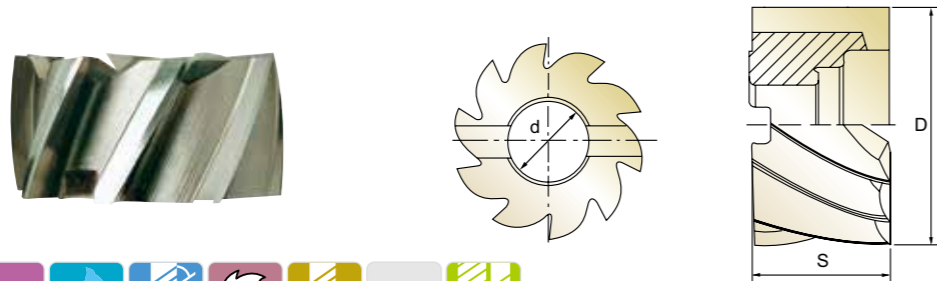

HSS Co8 DIN 841 W 4&6 42° UNCOATED p.C732

Unit : mm

EDP No.	Mill Diameter	Width of Face	Internal Diameter	No. of Teeth
	D	S	d	
E2676300	30.0	30	● 13	4
E2676400	40.0	20	● 16	4
E2676402	40.0	40	● 16	4
E2676500	50.0	25	22	6
E2676502	50.0	50	22	6
E2676600	60.0	30	27	6
E2676601	60.0	60	27	6
E2676750	75.0	75	27	6

- Tolerance of Internal Diameter = +0.018 ~ 0
- ▶ TIN-COATING, TiCN-COATING & TiAIN-COATING is available on your request.

HSS Co8 DIN 1880 W 4&6 42° UNCOATED p.C732

Unit : mm

EDP No.	Mill Diameter	Width of Face	Internal Diameter	No. of Teeth
	D	S	d	
E2676401	40.0	32	● 16	4
E2676501	50.0	36	22	6
E2676630	63.0	40	27	6
E2676800	80.0	45	27	6
E2676901	100.0	50	32	6

- Tolerance of Internal Diameter = +0.018 ~ 0
- ▶ TIN-COATING, TiCN-COATING & TiAIN-COATING is available on your request.

Mill Dia. Tolerance(mm)	Width of Face Tolerance(mm)	Internal Dia. Tolerance(mm)
+ 0.25	+ 0.5	+ 0.02
- 0.15	- 0	- 0

◎ : Excellent ○ : Good

ISO Material Description	P										M				K					
	Non-alloy steel					Low alloy steel					High alloyed steel, and tool steel		Stainless steel		Grey cast iron	Nodular cast iron		Malleable cast iron		
VDI 3323	1	2	3	4	5	6	7	8	9	10	11	12	13	14	15	16	17	18	19	20
HRc	13	25	28	32	38	10	29	32	38	15	35	15	23	10	10	26	3	25	21	21
HB	125	190	250	270	300	180	275	300	350	200	325	200	240	180	180	260	160	250	130	230
Recommended	○	○	○	○	○	○	○	○	○	○	○	○	○	○	○	○	○	○	○	○

ISO Material Description	N										S					H					
	Aluminum-wrought alloy		Aluminum-cast, alloyed		Copper and Copper Alloys (Bronze / Brass)		Non Metallic Materials		Heat Resistant Super Alloys					Titanium Alloys		Hardened steel	Chilled Cast Iron	Hardened Cast Iron			
VDI 3323	21	22	23	24	25	26	27	28	29	30	31	32	33	34	35	36	37	38	39	40	41
HRc	15	30	25	38	34	15	30	25	38	34	55	60	42	55	55	60	42	55	40	41	
HB	60	100	75	90	130	110	90	100	200	280	250	350	320	400 Rm	1050 Rm	550	630	400	550		
Recommended	◎	◎	◎	◎	◎	◎	◎	◎	◎	◎	◎	◎	◎	◎	◎	◎	◎	◎	◎	◎	

HSSCo8, MULTI FLUTE ROUGHING SHELL END MILL - COARSE

- HSSCo8, MULTI SCHNEIDEN WALZENSTIRN-SCHRUPPFRÄSER - GROBES
- Fraise HSSCo8, multi-dents trou lisse, ébauche, pas grossier
- FRESA CILINDRICA FRONTALE MULTI TAGLIENTE, PER SGROSSATURA

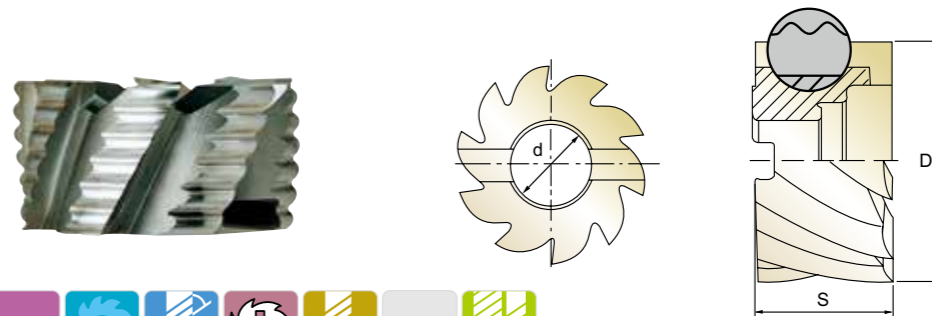

HSS Co8 DIN 841 NR 6-12 30° UNCOATED p.C733

Unit : mm

EDP No.	Mill Diameter	Width of Face	Internal Diameter	No. of Teeth
	D	S	d	
E2677401	40.0	40	● 16	6
E2677501	50.0	50	22	8
E2677600	60.0	30	27	8
E2677601	60.0	60	27	8
E2677750	75.0	35	27	10
E2677751	75.0	75	27	10
E2677900	90.0	35	27	10
E2677902	110.0	35	32	12

- Tolerance of Internal Diameter = +0.018 ~ 0
- ▶ TIN-COATING, TiCN-COATING & TiAIN-COATING is available on your request.

HSS Co8 DIN 1880 NR 6-12 30° UNCOATED p.C733

Unit : mm

EDP No.	Mill Diameter	Width of Face	Internal Diameter	No. of Teeth
	D	S	d	
E2677400	40.0	32	● 16	6
E2677500	50.0	36	22	8
E2677630	63.0	40	27	8
E2677800	80.0	45	27	10
E2677901	100.0	50	32	10
E2677903	125.0	56	40	12
E2677904	160.0	63	50	12

- Tolerance of Internal Diameter = +0.018 ~ 0
- ▶ TIN-COATING, TiCN-COATING & TiAIN-COATING is available on your request.

Mill Dia. Tolerance(mm)	Width of Face Tolerance(mm)	Internal Dia. Tolerance(mm)
+ 0.25	+ 0.5	+ 0.02
- 0.15	- 0	- 0

◎ : Excellent ○ : Good

ISO Material Description	P										M				K					
	Non-alloy steel					Low alloy steel					High alloyed steel, and tool steel		Stainless steel		Grey cast iron	Nodular cast iron		Malleable cast iron		
VDI 3323	1	2	3	4	5	6	7	8	9	10	11	12	13	14	15	16	17	18	19	20
HRc	13	25	28	32	38	10	29	32	38	15	35	15	23	10	10	26	3	25	21	21
HB	125	190	250	270	300	180	275	300	350	200	325	200	240	180	180	260	160	250	130	230
Recommended	◎	◎	◎	◎	◎	◎	◎	◎	◎	◎	◎	◎	◎	◎	◎	◎	◎	◎	◎	◎

ISO Material Description	N										S					H					
	Aluminum-wrought alloy		Aluminum-cast, alloyed		Copper and Copper Alloys (Bronze / Brass)		Non Metallic Materials		Heat Resistant Super Alloys					Titanium Alloys		Hardened steel	Chilled Cast Iron	Hardened Cast Iron			
VDI 3323	21	22	23	24	25	26	27	28	29	30	31	32	33	34	35	36	37	38	39	40	41
HRc	15	30	25	38	34	15	30	25	38	34	55	60	42	55	55	60	42	55	40	41	
HB	60	100	75	90	130	110	90	100	200	280	250	350	320	400 Rm	1050 Rm	550	630	400	550		
Recommended	◎	◎	◎	◎	◎	◎	◎	◎	◎	◎	◎	◎	◎	◎	◎	◎	◎	◎	◎	◎	



E2678 SERIES

HSSCo8, MULTI FLUTE ROUGHING SHELL END MILL - FINE

- HSSCo8, MULTI SCHNEIDEN WALZENSTIRN-SCHRUPPFRÄSER - FEINES
- Fraise HSSCo8, multi-dents trou lisse, ébauche, pas fin
- FRESA CILINDRICA FRONTALE MULTI TAGLIENTE, PER SGROSSATURA

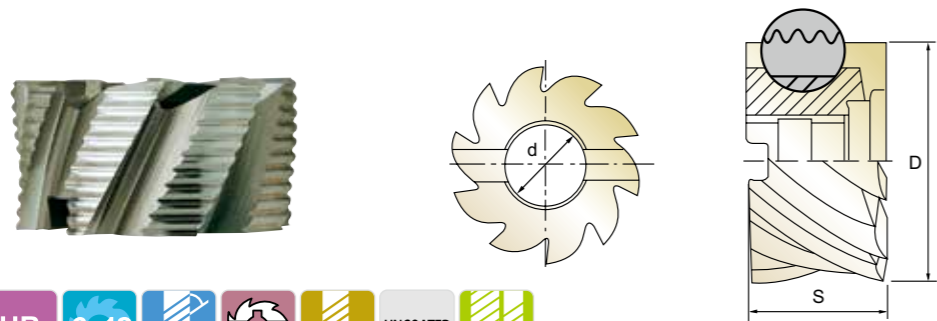

HSS Co8 DIN 841 HR 6-12 30° UNCOATED p.C733

Unit : mm

EDP No.	Mill Diameter	Width of Face	Internal Diameter	No. of Teeth
	D	S	d	
E2678401	40.0	40	● 16	6
E2678501	50.0	50	22	8
E2678600	60.0	30	27	8
E2678601	60.0	60	27	8
E2678750	75.0	35	27	10
E2678751	75.0	75	27	10
E2678900	90.0	35	27	10
E2678902	110.0	35	32	12

- Tolerance of Internal Diameter = +0.018 ~ 0
- ▶ TIN-COATING, TiCN-COATING & TiAIN-COATING is available on your request.

HSS Co8 DIN 1880 HR 6-12 30° UNCOATED p.C733

Unit : mm

EDP No.	Mill Diameter	Width of Face	Internal Diameter	No. of Teeth
	D	S	d	
E2678400	40.0	32	● 16	6
E2678500	50.0	36	22	8
E2678630	63.0	40	27	8
E2678800	80.0	45	27	10
E2678901	100.0	50	32	10
E2678903	125.0	56	40	12
E2678904	160.0	63	50	12

- Tolerance of Internal Diameter = +0.018 ~ 0
- ▶ TIN-COATING, TiCN-COATING & TiAIN-COATING is available on your request.

Mill Dia. Tolerance(mm)	Width of Face Tolerance(mm)	Internal Dia. Tolerance(mm)
+0.25 -0.15	+0.5 -0	+0.02 -0

◎ : Excellent ○ : Good

ISO Material Description	P										M				K					
	Non-alloy steel					Low alloy steel					High alloyed steel, and tool steel		Stainless steel		Grey cast iron	Nodular cast iron		Malleable cast iron		
VDI 3323	1	2	3	4	5	6	7	8	9	10	11	12	13	14	15	16	17	18	19	20
HRc	13	25	28	32	38	10	29	32	38	45	15	35	23	10	10	26	3	25	21	21
HB	125	190	250	270	300	180	275	300	350	200	325	200	240	180	180	260	160	250	130	230
Recommended	◎	◎	◎	◎	◎	◎	◎	◎	◎	◎	◎	◎	◎	◎	◎	◎	◎	◎	◎	◎

ISO Material Description	N										S					H					
	Aluminum-wrought alloy		Aluminum-cast, alloyed			Copper and Copper Alloys (Bronze / Brass)					Non Metallic Materials		Heat Resistant Super Alloys			Titanium Alloys	Hardened steel	Chilled Cast Iron	Hardened Cast Iron		
VDI 3323	21	22	23	24	25	26	27	28	29	30	31	32	33	34	35	36	37	38	39	40	41
HRc	15	30	25	38	34						200	280	250	350	320	400 Rm	1050 Rm	550	630	400	550
HB	60	100	75	90	130	110	90	100													
Recommended	◎	◎	◎	◎	◎	◎	◎	◎	◎	◎	◎	◎	◎	◎	◎	◎	◎	◎	◎	◎	◎



E2679 SERIES

HSSCo8, MULTI FLUTE ROUGHING & FINISHING SHELL END MILL

- HSSCo8, MULTI SCHNEIDEN WALZENSTIRN-SCHRUPPSCHLICHTFRÄSER
- Fraise HSSCo8, multi-dents trou lisse, ébauche et finition
- FRESA CILINDRICA FRONTALE MULTI TAGLIENTE, SEMI FINITURA

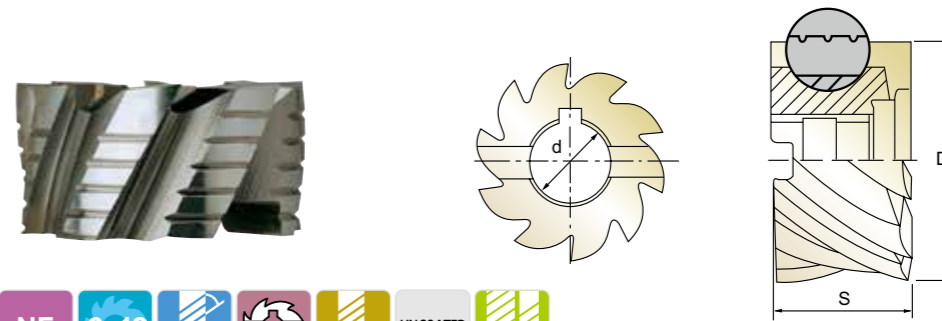

HSS Co8 DIN 841 NF 6-12 30° UNCOATED p.C733

Unit : mm

EDP No.	Mill Diameter	Width of Face	Internal Diameter	No. of Teeth
	D	S	d	
E2679401	40.0	40	● 16	6
E2679501	50.0	50	22	8
E2679600	60.0	30	27	8
E2679601	60.0	60	27	8
E2679750	75.0	35	27	10
E2679751	75.0	75	27	10
E2679900	90.0	35	27	10
E2679902	110.0	35	32	12

- Tolerance of Internal Diameter = +0.018 ~ 0
- ▶ TIN-COATING, TiCN-COATING & TiAIN-COATING is available on your request.

HSS Co8 DIN 1880 NF 6-12 30° UNCOATED p.C733

Unit : mm

EDP No.	Mill Diameter	Width of Face	Internal Diameter	No. of Teeth
	D	S	d	
E2679400	40.0	32	● 16	6
E2679500	50.0	36	22	8
E2679630	63.0	40	27	8
E2679800	80.0	45	27	10
E2679901	100.0	50	32	10
E2679903	125.0	56	40	12
E2679904	160.0	63	50	12

- Tolerance of Internal Diameter = +0.018 ~ 0
- ▶ TIN-COATING, TiCN-COATING & TiAIN-COATING is available on your request.

Mill Dia. Tolerance(mm)	Width of Face Tolerance(mm)	Internal Dia. Tolerance(mm)
+0.25 -0.15	+0.5 -0	+0.02 -0

◎ : Excellent ○ : Good

ISO Material Description	P										M				K					
	Non-alloy steel					Low alloy steel					High alloyed steel, and tool steel		Stainless steel		Grey cast iron	Nodular cast iron		Malleable cast iron		
VDI 3323	1	2	3	4	5	6	7	8	9	10	11	12	13	14	15	16	17	18	19	20
HRc	13	25	28	32	38	10	29	32	38	45	15	35	23	10	10	26	3	25	21	21
HB	125	190	250	270	300	180	275	300	350	200	325	200	240	180	180	260	160	250	130	230
Recommended	◎	◎	◎	◎	◎	◎	◎	◎	◎	◎	◎	◎	◎	◎	◎	◎	◎	◎	◎	◎

ISO Material Description	N										S					H					
	Aluminum-wrought alloy		Aluminum-cast, alloyed			Copper and Copper Alloys (Bronze / Brass)					Non Metallic Materials		Heat Resistant Super Alloys			Titanium Alloys	Hardened steel	Chilled Cast Iron	Hardened Cast Iron		
VDI 3323	21	22	23	24	25	26	27	28	29	30	31	32	33	34	35	36	37	38	39	40	41
HRc	15	30	25	38	34						200	280	250	350	320	400 Rm	1050 Rm	550	630	400	550
HB	60	100	75	90	130	110	90	100													
Recommended	◎	◎	◎	◎	◎	◎	◎	◎	◎	◎	◎	◎	◎	◎	◎	◎	◎	◎	◎	◎	◎



FLAT SHANK **E2498** SERIES

HSSCo8, 4 FLUTE CORNER ROUNDING CUTTERS

- HSSCo8, 4 SCHNEIDEN VIERTELKREISFRÄSER
- Fraise HSSCo8, 1/4 de cercle, 4 dents
- 4 TAGLIENTI PER RAGGIATURA DI SPIGOLI

▶ These tools can be adapted for many screw machine applications as end forming tools to form a specific radius.

▶ Dieses Werkzeug kann an vielen Scrow maschine als Finishingtool für spezielle Radien montiert werden.

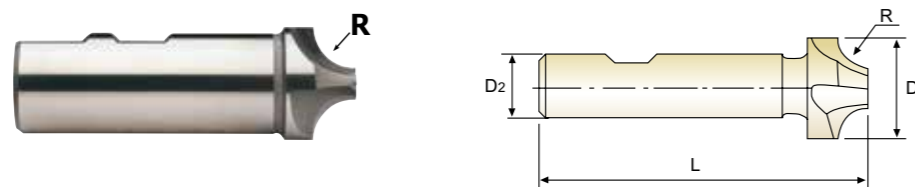

HSS Co8 DIN 6518 N 4 0° DIN 1835B UNCOATED p.C734

Unit : mm

EDP No.	Radius	Outside Diameter	Shank Diameter	Overall Length
	R(H11)	D	D2(h6)	L
E2498010	R1.0	8.0	10	60
E2498015	R1.5	9.0	10	60
E2498020	R2.0	10.0	10	60
E2498025	R2.5	11.0	10	60
E2498030	R3.0	12.0	12	60
E2498035	R3.5	13.0	12	60
E2498040	R4.0	14.0	12	60
E2498045	R4.5	15.0	12	60
E2498050	R5.0	16.0	12	60
E2498055	R5.5	19.0	16	67
E2498060	R6.0	20.0	16	67
E2498065	R6.5	21.0	16	71
E2498070	R7.0	22.0	16	71
E2498075	R7.5	23.0	16	71
E2498080	R8.0	24.0	16	71
E2498085	R8.5	25.0	25	85
E2498090	R9.0	26.0	25	85
E2498095	R9.5	27.0	25	85

▶ TIN-COATING, TiCN-COATING & TiAIN-COATING is available on your request.

▶ NEXT PAGE

Tolerances according to DIN 7160 & 7161

	Nominal-Diameter in mm					
	from 1 to 3	over 3 to 6	over 6 to 10	over 10 to 18	over 18 to 30	over 30 to 50
H11	+60 0	+75 0	+90 0	+110 0	+130 0	+160 0
h6	0 -6	0 -8	0 -9	0 -11	0 -13	0 -16

◎ : Excellent ○ : Good

ISO	P										M				K																												
	Non-alloy steel					Low alloy steel					High alloyed steel, and tool steel				Stainless steel		Grey cast iron		Nodular cast iron			Malleable cast iron																					
Material Description	1	2	3	4	5	6	7	8	9	10	11	12	13	14	15	16	17	18	19	20	21	22	23	24	25	26	27	28	29	30	31	32	33	34	35	36	37	38	39	40	41		
VDI 3323	1	2	3	4	5	6	7	8	9	10	11	12	13	14	15	16	17	18	19	20	21	22	23	24	25	26	27	28	29	30	31	32	33	34	35	36	37	38	39	40	41		
HRc	13	25	28	32	38	42	48	52	58	62	68	72	78	82	88	92	98	102	108	112	118	122	128	132	138	142	148	152	158	162	168	172	178	182	188	192	198	202	208	212			
HB	125	190	250	270	300	180	275	300	350	200	325	200	240	180	180	260	160	250	130	230	160	250	130	230																			
Recommended	◎	◎	◎	◎	◎	◎	◎	◎	◎	◎	◎	◎	◎	◎	◎	◎	◎	◎	◎	◎	◎	◎	◎	◎	◎	◎	◎	◎	◎	◎	◎	◎	◎	◎	◎	◎	◎	◎	◎	◎	◎	◎	◎



FLAT SHANK **E2498** SERIES

HSSCo8, 4 FLUTE CORNER ROUNDING CUTTERS

- HSSCo8, 4 SCHNEIDEN VIERTELKREISFRÄSER
- Fraise HSSCo8, 1/4 de cercle, 4 dents
- 4 TAGLIENTI PER RAGGIATURA DI SPIGOLI

▶ These tools can be adapted for many screw machine applications as end forming tools to form a specific radius.

▶ Dieses Werkzeug kann an vielen Scrow maschine als Finishingtool für spezielle Radien montiert werden.

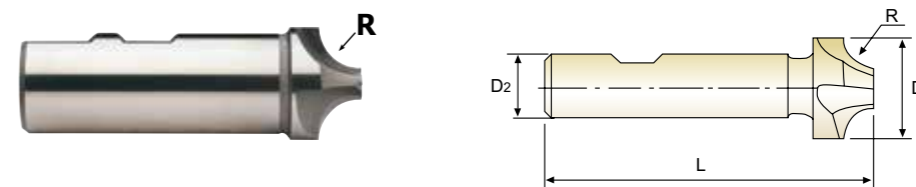

HSS Co8 DIN 6518 N 4 0° DIN 1835B UNCOATED p.C734

Unit : mm

EDP No.	Radius	Outside Diameter	Shank Diameter	Overall Length
	R(H11)	D	D2(h6)	L
E2498100	R10.0	28.0	25	85
E2498105	R10.5	31.0	25	90
E2498110	R11.0	32.0	25	90
E2498120	R12.0	34.0	25	90
E2498125	R12.5	41.0	25	100
E2498130	R13.0	42.0	25	100
E2498140	R14.0	44.0	25	100
E2498150	R15.0	46.0	25	100
E2498160	R16.0	48.0	25	100
E2498180	R18.0	52.0	32	112
E2498200	R20.0	56.0	32	112

▶ TIN-COATING, TiCN-COATING & TiAIN-COATING is available on your request.

Tolerances according to DIN 7160 & 7161

	Nominal-Diameter in mm					
	from 1 to 3	over 3 to 6	over 6 to 10	over 10 to 18	over 18 to 30	over 30 to 50
H11	+60 0	+75 0	+90 0	+110 0	+130 0	+160 0
h6	0 -6	0 -8	0 -9	0 -11	0 -13	0 -16

◎ : Excellent ○ : Good

ISO	P										M				K																												
	Non-alloy steel					Low alloy steel					High alloyed steel, and tool steel				Stainless steel		Grey cast iron		Nodular cast iron			Malleable cast iron																					
Material Description	1	2	3	4	5	6	7	8	9	10	11	12	13	14	15	16	17	18	19	20	21	22	23	24	25	26	27	28	29	30	31	32	33	34	35	36	37	38	39	40	41		
VDI 3323	1	2	3	4	5	6	7	8	9	10	11	12	13	14	15	16	17	18	19	20	21	22	23	24	25	26	27	28	29	30	31	32	33	34	35	36	37	38	39	40	41		
HRc	13	25	28	32	38	42	48	52	58	62	68	72	78	82	88	92	98	102	108	112	118	122	128	132	138	142	148	152	158	162	168	172	178	182	188	192	198	202	208	212			
HB	125	190	250	270	300	180	275	300	350	200	325	200	240	180	180	260	160	250	130	230	160	250	130	230																			
Recommended	◎	◎	◎	◎	◎	◎	◎	◎	◎	◎	◎	◎	◎	◎	◎	◎	◎	◎	◎	◎	◎	◎	◎	◎	◎	◎	◎	◎	◎	◎	◎	◎	◎	◎	◎	◎	◎	◎	◎	◎	◎	◎	◎



RECOMMENDED CUTTING CONDITIONS
EMPFOHLENE SCHNEIDPARAMETER

ML012, ML112, ML022, ML122 SERIES

MULTI FLUTE DOVETAIL CUTTERS TYPE 'A', 'C', 'E'

Vc = m/min.
fz = mm/tooth
RPM = rev./min.
FEED = mm/min.

ISO	VDI 3323	Material Description	Parameter	Diameter (Ø)						
				16.0	20.0	25.0	32.0	40.0	50.0	63.0
P	1	Non-alloy steel	Vc	30	30	30	30	30	30	30
			fz	0.03	0.037	0.026	0.042	0.043	0.03	0.031
			RPM	597	477	382	298	239	191	152
	FEED		107	106	79	125	123	92	75	
	2		Vc	15	15	15	15	15	15	15
			fz	0.031	0.036	0.031	0.041	0.043	0.026	0.031
			RPM	298	239	191	149	119	95	76
	FEED		56	52	47	61	62	40	38	
	3-4		Vc	10	10	10	10	10	10	10
			fz	0.031	0.035	0.028	0.04	0.042	0.03	0.033
			RPM	199	159	127	99	80	64	51
FEED	37	33	29	40	40	31	27			
5	Vc	10	10	10	10	10	10	10		
	fz	0.021	0.02	0.02	0.02	0.022	0.02	0.023		
	RPM	199	159	127	99	80	64	51		
FEED	25	19	20	20	21	20	19			
6	Vc	15	15	15	15	15	15	15		
	fz	0.031	0.036	0.031	0.041	0.043	0.026	0.031		
	RPM	298	239	191	149	119	95	76		
FEED	56	52	47	61	62	40	38			
7	Vc	10	10	10	10	10	10	10		
	fz	0.031	0.035	0.028	0.04	0.042	0.03	0.033		
	RPM	199	159	127	99	80	64	51		
FEED	37	33	29	40	40	31	27			
8-9	Vc	10	10	10	10	10	10	10		
	fz	0.021	0.02	0.02	0.02	0.022	0.02	0.023		
	RPM	199	159	127	99	80	64	51		
FEED	25	19	20	20	21	20	19			
10	Vc	15	15	15	15	15	15	15		
	fz	0.031	0.036	0.031	0.041	0.043	0.026	0.031		
	RPM	298	239	191	149	119	95	76		
FEED	56	52	47	61	62	40	38			
11.1	Vc	10	10	10	10	10	10	10		
	fz	0.021	0.02	0.02	0.02	0.022	0.02	0.023		
	RPM	199	159	127	99	80	64	51		
FEED	25	19	20	20	21	20	19			
N	21~25	Aluminum-wrought alloy, Aluminum-cast, alloyed	Vc	95	85	90	90	95	85	90
			fz	0.03	0.04	0.029	0.041	0.042	0.03	0.033
			RPM	1890	1353	1146	895	756	541	455
			FEED	340	325	266	367	381	260	240



RECOMMENDED CUTTING CONDITIONS
EMPFOHLENE SCHNEIDPARAMETER

ML032, ML132, ML042, ML142 SERIES

MULTI FLUTE DOVETAIL CUTTERS TYPE 'B', 'D', 'F'

Vc = m/min.
fz = mm/tooth
RPM = rev./min.
FEED = mm/min.

ISO	VDI 3323	Material Description	Parameter	Diameter (Ø)			
				16.0	20.0	25.0	32.0
P	1	Non-alloy steel	Vc	30	30	30	30
			fz	0.03	0.037	0.026	0.042
			RPM	597	477	382	298
	FEED		107	106	79	125	
	2		Vc	15	15	15	15
			fz	0.031	0.036	0.031	0.041
			RPM	298	239	191	149
	FEED		56	52	47	61	
	3-4		Vc	10	10	10	10
			fz	0.031	0.035	0.028	0.04
			RPM	199	159	127	99
FEED	37	33	29	40			
5	Vc	10	10	10	10		
	fz	0.021	0.02	0.02	0.02		
	RPM	199	159	127	99		
FEED	25	19	20	20			
6	Vc	15	15	15	15		
	fz	0.031	0.036	0.031	0.041		
	RPM	298	239	191	149		
FEED	56	52	47	61			
7	Vc	10	10	10	10		
	fz	0.031	0.035	0.028	0.04		
	RPM	199	159	127	99		
FEED	37	33	29	40			
8-9	Vc	10	10	10	10		
	fz	0.021	0.02	0.02	0.02		
	RPM	199	159	127	99		
FEED	25	19	20	20			
10	Vc	15	15	15	15		
	fz	0.031	0.036	0.031	0.041		
	RPM	298	239	191	149		
FEED	56	52	47	61			
11.1	Vc	10	10	10	10		
	fz	0.021	0.02	0.02	0.02		
	RPM	199	159	127	99		
FEED	25	19	20	20			
N	21~25	Aluminum-wrought alloy, Aluminum-cast, alloyed	Vc	95	85	90	90
			fz	0.03	0.04	0.029	0.041
			RPM	1890	1353	1146	895
			FEED	340	325	266	367



RECOMMENDED CUTTING CONDITIONS
EMPFOHLENE SCHNEIDPARAMETER

ML092 SERIES

MULTI FLUTES SIDE AND FACE MILLING CUTTERS WITH STRAIGHT TEETH

Vc = m/min.
fz = mm/tooth
RPM = rev./min.
FEED = mm/min.

ISO	VDI 3323	Material Description	Parameter	Diameter (Ø)				
				50.0	63.0	80.0	100.0	125.0
P	1	Non-alloy steel	Vc	25	25	25	25	25
			fz	0.045	0.058	0.06	0.063	0.066
			RPM	159	126	99	80	64
			FEED	129	161	143	130	126
			Vc	20	20	20	20	20
	2	Non-alloy steel	fz	0.04	0.036	0.041	0.038	0.05
			RPM	127	101	80	64	51
	3-4	Non-alloy steel	FEED	92	80	78	63	76
			Vc	15	15	15	15	15
	5	Non-alloy steel	fz	0.034	0.031	0.033	0.034	0.042
			RPM	95	76	60	48	38
6	Non-alloy steel	FEED	58	52	47	42	48	
		Vc	10	10	10	10	10	
7	Non-alloy steel	fz	0.031	0.029	0.03	0.03	0.036	
		RPM	64	51	40	32	25	
8-9	Non-alloy steel	FEED	36	32	29	25	28	
		Vc	20	20	20	20	20	
10	Non-alloy steel	fz	0.04	0.036	0.041	0.038	0.05	
		RPM	127	101	80	64	51	
11.1	Non-alloy steel	FEED	92	80	78	63	76	
		Vc	10	10	10	10	10	
N	21~25	Aluminum-wrought alloy, Aluminum-cast, alloyed	fz	0.031	0.029	0.03	0.03	0.036
			RPM	64	51	40	32	25
N	21~25	Aluminum-wrought alloy, Aluminum-cast, alloyed	FEED	36	32	29	25	28
			Vc	100	100	100	100	100
N	21~25	Aluminum-wrought alloy, Aluminum-cast, alloyed	fz	0.018	0.023	0.026	0.024	0.033
			RPM	637	505	398	318	255
N	21~25	Aluminum-wrought alloy, Aluminum-cast, alloyed	FEED	206	256	248	199	252

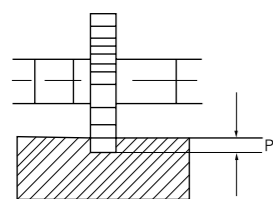

MILLING DEPTH P = WIDTH OF FACES



RECOMMENDED CUTTING CONDITIONS
EMPFOHLENE SCHNEIDPARAMETER

ML102 SERIES

MULTI FLUTE SIDE AND FACE MILLING CUTTERS WITH STAGGERED TEETH

Vc = m/min.
fz = mm/tooth
RPM = rev./min.
FEED = mm/min.

ISO	VDI 3323	Material Description	Parameter	Diameter (Ø)						
				50.0	63.0	80.0	100.0	125.0	160.0	200.0
P	1	Non-alloy steel	Vc	25	25	25	25	25	25	25
			fz	0.058	0.08	0.081	0.081	0.072	0.081	0.079
			RPM	159	126	99	80	64	50	40
			FEED	129	162	145	129	101	105	94
			Vc	20	20	20	20	20	20	20
	2	Non-alloy steel	fz	0.053	0.052	0.055	0.05	0.055	0.05	0.048
			RPM	127	101	80	64	51	40	32
	3-4	Non-alloy steel	FEED	94	84	79	64	62	52	46
			Vc	15	15	15	15	15	15	15
	5	Non-alloy steel	fz	0.044	0.043	0.044	0.044	0.045	0.044	0.041
			RPM	95	76	60	48	38	30	24
6	Non-alloy steel	FEED	59	52	47	42	38	34	29	
		Vc	10	10	10	10	10	10	10	
7	Non-alloy steel	fz	0.039	0.04	0.04	0.039	0.039	0.04	0.039	
		RPM	64	51	40	32	25	20	16	
8-9	Non-alloy steel	FEED	35	32	29	25	22	21	19	
		Vc	20	20	20	20	20	20	20	
10	Non-alloy steel	fz	0.053	0.052	0.055	0.05	0.055	0.05	0.048	
		RPM	127	101	80	64	51	40	32	
11.1	Non-alloy steel	FEED	94	84	79	64	62	52	46	
		Vc	10	10	10	10	10	10	10	
N	21~25	Aluminum-wrought alloy, Aluminum-cast, alloyed	fz	0.039	0.04	0.04	0.039	0.039	0.04	0.039
			RPM	64	51	40	32	25	20	16
N	21~25	Aluminum-wrought alloy, Aluminum-cast, alloyed	FEED	35	32	29	25	22	21	19
			Vc	100	100	100	100	100	100	100
N	21~25	Aluminum-wrought alloy, Aluminum-cast, alloyed	fz	0.023	0.031	0.035	0.031	0.036	0.029	0.031
			RPM	637	505	398	318	255	199	159
N	21~25	Aluminum-wrought alloy, Aluminum-cast, alloyed	FEED	205	251	251	197	202	150	148

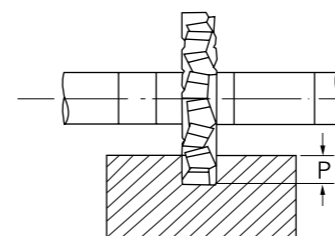

MILLING DEPTH P = WIDTH OF FACES



RECOMMENDED CUTTING CONDITIONS
EMPFOHLENE SCHNEIDPARAMETER

E2675 SERIES MULTI FLUTE SHELL END MILL

Vc = m/min.
fz = mm/tooth
RPM = rev./min.
FEED = mm/min.

ISO	VDI 3323	Material Description	Ae	Ap	Parameter	Diameter (Ø)						
						40.0	50.0	63.0	80.0	100.0	125.0	160.0
P	1-2	Non-alloy steel	0.75D	0.25D	Vc	30	30	30	30	30	30	30
					fz	0.07	0.078	0.092	0.1	0.115	0.12	0.131
					RPM	239	191	152	119	95	76	60
	FEED		134	119	112	119	110	110	109			
	3-4		Vc	25	25	25	25	25	30			
			fz	0.075	0.077	0.091	0.1	0.119	0.113	0.119		
			RPM	199	159	126	99	80	64	60		
	FEED		119	98	92	99	95	86	99			
	5		Vc	20	20	20	20	20	20			
			fz	0.071	0.078	0.09	0.094	0.117	0.108	0.116		
			RPM	159	127	101	80	64	51	40		
FEED	90	79	73	75	74	66	65					
6	Vc	30	30	30	30	30	30					
	fz	0.07	0.078	0.092	0.1	0.115	0.12	0.131				
	RPM	239	191	152	119	95	76	60				
FEED	134	119	112	119	110	110	109					
7	Vc	25	25	25	25	25	30					
	fz	0.075	0.077	0.091	0.1	0.119	0.113	0.119				
	RPM	199	159	126	99	80	64	60				
FEED	119	98	92	99	95	86	99					
8	Vc	20	20	20	20	20	20					
	fz	0.071	0.078	0.09	0.094	0.117	0.108	0.116				
	RPM	159	127	101	80	64	51	40				
FEED	90	79	73	75	74	66	65					
9	Vc	10	10	10	10	10	10					
	fz	0.078	0.08	0.1	0.1	0.117	0.146	0.125				
	RPM	80	64	51	40	32	25	20				
FEED	50	41	40	40	37	45	35					
10	Vc	30	30	30	30	30	30					
	fz	0.07	0.078	0.092	0.1	0.115	0.12	0.131				
	RPM	239	191	152	119	95	76	60				
FEED	134	119	112	119	110	110	109					
11.1	Vc	20	20	20	20	20	20					
	fz	0.071	0.078	0.09	0.094	0.117	0.108	0.116				
	RPM	159	127	101	80	64	51	40				
FEED	90	79	73	75	74	66	65					

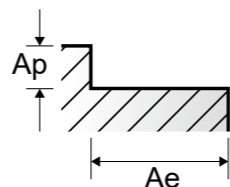

E2676 SERIES MULTI FLUTE SHELL END MILL for ALUMINUM

ISO	VDI 3323	Material Description	Ae	Ap	Parameter	Diameter (Ø)							
						30.0	40.0	50.0	60.0	63.0	75.0	80.0	100.0
N	21~25	Aluminum-wrought alloy, Aluminum-cast, alloyed	0.75D	0.25D	Vc	100	105	95	95	95	105	100	
					fz	0.05	0.06	0.069	0.1	0.115	0.13	0.128	0.151
					RPM	1061	836	605	504	480	446	398	318
					FEED	212	201	250	302	331	348	306	288

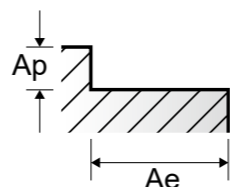

RECOMMENDED CUTTING CONDITIONS
EMPFOHLENE SCHNEIDPARAMETER

E2677, E2678 SERIES MULTI FLUTE ROUGHING SHELL END MILL

Vc = m/min.
fz = mm/tooth
RPM = rev./min.
FEED = mm/min.

ISO	VDI 3323	Material Description	Ae	Ap	Parameter	Diameter (Ø)						
						40.0	50.0	63.0	80.0	100.0	125.0	160.0
P	1-2	Non-alloy steel	0.75D	0.25D	Vc	30	30	30	30	30	30	30
					fz	0.069	0.078	0.092	0.1	0.115	0.12	0.153
					RPM	239	191	152	119	95	76	60
	FEED		99	119	112	119	110	110	110			
	3-4		Vc	25	25	25	25	25	30			
			fz	0.071	0.077	0.091	0.1	0.119	0.113	0.139		
			RPM	199	159	126	99	80	64	60		
	FEED		85	98	92	99	95	86	100			
	5		Vc	20	20	20	20	20	20			
			fz	0.071	0.078	0.09	0.094	0.117	0.108	0.135		
			RPM	159	127	101	80	64	51	40		
FEED	68	79	73	75	74	66	64					
6	Vc	30	30	30	30	30	30					
	fz	0.069	0.078	0.092	0.1	0.115	0.12	0.153				
	RPM	239	191	152	119	95	76	60				
FEED	99	119	112	119	110	110	110					
7	Vc	25	25	25	25	25	30					
	fz	0.071	0.077	0.091	0.1	0.119	0.113	0.139				
	RPM	199	159	126	99	80	64	60				
FEED	85	98	92	99	95	86	100					
8	Vc	20	20	20	20	20	20					
	fz	0.071	0.078	0.09	0.094	0.117	0.108	0.135				
	RPM	159	127	101	80	64	51	40				
FEED	68	79	73	75	74	66	64					
9	Vc	10	10	10	10	10	10					
	fz	0.073	0.08	0.1	0.1	0.117	0.146	0.146				
	RPM	80	64	51	40	32	25	20				
FEED	35	41	40	40	37	45	35					
10	Vc	30	30	30	30	30	30					
	fz	0.069	0.078	0.092	0.1	0.115	0.12	0.153				
	RPM	239	191	152	119	95	76	60				
FEED	99	119	112	119	110	110	110					
11.1	Vc	20	20	20	20	20	20					
	fz	0.071	0.078	0.09	0.094	0.117	0.108	0.135				
	RPM	159	127	101	80	64	51	40				
FEED	68	79	73	75	74	66	64					

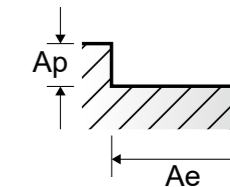

E2679 SERIES MULTI FLUTE ROUGHING & FINISHING SHELL END MILL

ISO	VDI 3323	Material Description	Ae	Ap	Parameter	Diameter (Ø)						
						40.0	50.0	63.0	80.0	100.0	125.0	160.0
P	1-2	Non-alloy steel	0.75D	0.25D	Vc	30	30	30	30	30	30	30
					fz	0.069	0.078	0.092	0.1	0.115	0.12	0.153
					RPM	239	191	152	119	95	76	60
	FEED		99	119	112	119	110	110	110			
	3-4		Vc	25	25	25	25	25	30			
			fz	0.071	0.077	0.091	0.1	0.119	0.113	0.139		
			RPM	199	159	126	99	80	64	60		
	FEED		85	98	92	99	95	86	100			
	5		Vc	20	20	20	20	20	20			
			fz	0.071	0.078	0.09	0.094	0.117	0.108	0.135		
			RPM	159	127	101	80	64	51	40		
FEED	68	79	73	75	74	66	64					
6	Vc	30	30	30	30	30	30					
	fz	0.069	0.078	0.092	0.1	0.115	0.12	0.153				
	RPM	239	191	152	119	95	76	60				
FEED	99	119	112	119	110	110	110					
7	Vc	25	25	25	25	25	30					
	fz	0.071	0.077	0.091	0.1	0.119	0.113	0.139				
	RPM	199	159	126	99	80	64	60				
FEED	85	98	92	99	95	86	100					
8	Vc	20	20	20	20	20	20					
	fz	0.071	0.078	0.09	0.094	0.117	0.108	0.135				
	RPM	159	127	101	80	64	51	40				
FEED	68	79	73	75	74	66	64					
9	Vc	10	10	10	10	10	10					
	fz	0.073	0.08	0.1	0.1	0.117	0.146	0.146				
	RPM	80	64	51	40	32	25	20				
FEED	35	41	40	40	37	45	35					
10	Vc	30	30	30	30	30	30					
	fz	0.069	0.078	0.092	0.1	0.115	0.12	0.153				
	RPM	239	191	152	119	95	76	60				
FEED	99	119	112	119	110	110	110					
11.1	Vc	20	20	20	20	20	20					
	fz	0.071	0.078	0.09	0.094	0.117	0.108	0.135				
	RPM	159	127	101	80	64	51	40				
FEED	68	79	73	75	74	66	64					



RECOMMENDED CUTTING CONDITIONS
EMPFOHLENE SCHNEIDPARAMETER

E2498 SERIES

4 FLUTE CORNER ROUNDING CUTTERS

Vc = m/min.
fz = mm/tooth
RPM = rev./min.
FEED = mm/min.

ISO	VDI 3323	Material Description	Parameter	Diameter (Ø)											
				8.0	9.0	10.0	11.0	12.0	14.0	16.0	20.0	24.0	28.0	34.0	48.0
P	1	Non-alloy steel	Vc	20	20	20	20	20	20	20	20	20	20	20	20
			fz	0.017	0.022	0.02	0.021	0.021	0.025	0.029	0.032	0.038	0.042	0.049	0.058
			RPM	796	707	637	579	531	455	398	318	265	227	187	133
	FEED		54	62	51	49	45	45	46	41	40	38	37	31	
	2		Vc	15	15	15	15	15	15	15	15	15	15	15	15
			fz	0.015	0.016	0.016	0.019	0.019	0.023	0.029	0.033	0.039	0.04	0.048	0.053
			RPM	597	531	477	434	398	341	298	239	199	171	140	99
	FEED		36	34	31	33	30	31	35	32	31	27	27	21	
	3-4		Vc	10	10	10	10	10	10	10	10	10	10	10	10
			fz	0.018	0.023	0.02	0.024	0.024	0.023	0.03	0.034	0.04	0.05	0.048	0.05
			RPM	398	354	318	289	265	227	199	159	133	114	94	66
	FEED		29	33	25	28	25	21	24	22	21	23	18	13	
6	Vc	15	15	15	15	15	15	15	15	15	15	15	15		
	fz	0.015	0.016	0.016	0.019	0.019	0.023	0.029	0.033	0.039	0.04	0.048	0.053		
	RPM	597	531	477	434	398	341	298	239	199	171	140	99		
FEED	36	34	31	33	30	31	35	32	31	27	27	21			
7-8	Vc	10	10	10	10	10	10	10	10	10	10	10	10		
	fz	0.018	0.023	0.02	0.024	0.024	0.023	0.03	0.034	0.04	0.05	0.048	0.05		
	RPM	398	354	318	289	265	227	199	159	133	114	94	66		
FEED	29	33	25	28	25	21	24	22	21	23	18	13			
10	Vc	15	15	15	15	15	15	15	15	15	15	15	15		
	fz	0.015	0.016	0.016	0.019	0.019	0.023	0.029	0.033	0.039	0.04	0.048	0.053		
	RPM	597	531	477	434	398	341	298	239	199	171	140	99		
FEED	36	34	31	33	30	31	35	32	31	27	27	21			
11.1	Vc	10	10	10	10	10	10	10	10	10	10	10	10		
	fz	0.018	0.023	0.02	0.024	0.024	0.023	0.03	0.034	0.04	0.05	0.048	0.05		
	RPM	398	354	318	289	265	227	199	159	133	114	94	66		
FEED	29	33	25	28	25	21	24	22	21	23	18	13			
N	21~25	Aluminum-wrought alloy, Aluminum-cast, alloyed	Vc	90	80	90	85	90	90	80	90	90	85	85	90
			fz	0.018	0.021	0.02	0.023	0.022	0.025	0.031	0.034	0.038	0.045	0.05	0.058
			RPM	3581	2829	2865	2460	2387	2046	1592	1432	1194	966	796	597
			FEED	258	238	229	226	210	205	197	195	181	174	159	138