

YE-TP23 EUROPE

BEST VALUE IN THE WORLD OF CUTTING TOOLS



FOR TITANIUM, STAINLESS STEELS AND ALLOY STEELS :

TOUGH MATERIALS
TAKE IT ON WITH

TitaNox Power



INDUSTRY-LEADING SOLID CARBIDE END MILLS

HIGH-PERFORMANCE
MACHINING MADE EASY:

- Variable Helix and Pitch
- 4 Flute and 5 Flute
- Square End, Chamfer and Radius
- Standard and Extended Lengths
- Inch and Metric Sizes
- 5 Flute Heavy Cutting Solution
TitaNox-Power HPC **NEW**

Take It On With TitaNox Power

HIGH-PERFORMANCE MACHINING MADE EASY.

-  Titanium
-  Stainless Steels
-  Alloy Steels



If you've been looking for a superior carbide end mill that won't back down when the going gets tough, it's time you look at TitaNox-Power.

The TitaNox-Power line is built to take on titanium, stainless steels, alloy steels, and more. With a choice of 4- and 5 flute designs and extra-rigid high-speed performance, TitaNox-Power makes the perfect match for aerospace, power generation and medical applications.

TitaNox-Power - Nothing Cuts Better.

With more choices in high-performance carbide end mills, YG-1 is the undisputed leader in end mill offerings. And with the TitaNox-Power line, you have a full selection of extremely durable end mills built to take on the toughest materials in the business. From titanium to stainless steel and more - TitaNox-Power rules. In either 4 flute or 5 flute configurations you get:

- ▶ YG-1 advanced coating for better wear resistance
- ▶ Better thermal stability
- ▶ Optimized edge design provides excellent performance in heavy cutting applications
- ▶ Excellent performance in difficult-to-machine materials
- ▶ Perfect solution for aerospace, power generation and medical applications
- ▶ Premium grade substrate for longer tool life

TitaNox-Power 4 FLUTE DOUBLE CORE END MILLS



Let the Chips Fly.

For heavy cutting in slotting and profiling applications, our true double-core design provides faster chip evacuation and improved dimensional stability. Experience what a difference double-core design can make in your operation.

- ▶ Highly rigid double core adds stability and improves rigidity
- ▶ Unique 4 flute design provides excellent chip evacuation
- ▶ Variable flute design featuring multiple helix helps increase performance, reduce vibration and eliminate chatter

TitaNox-Power 5 FLUTE MULTIPLE HELIX END MILLS



Strong Performance — Right to the Finish.

These new 5 flute end mills are built to handle high-speed machining with fine finishing ability.

- ▶ 5 flute multiple helix design for fast, fine finishing in tough materials
- ▶ Multiple-helix geometry delivers smooth cutting with reduced chatter
- ▶ The perfect choice for profiling, finishing, peel milling operations and more
- ▶ New HPC Solution for Heavy Cutting Applications

CASE STUDY

4 Flute Double Core End Mills vs. Competitors

Cutting Conditions	
Milling Method	Slotting 
Work Material	- DIN : Ti6Al4V (Titanium) - WR : 3.7165.1
Size	Ø12(R1) x Ø12 x 26 x 80
RPM	1,591 rev./min.
FEED	254 mm/min.
Axial Depth	12mm
Coolant	Wet Cut
Overhang	36mm
Machine	Machining Center

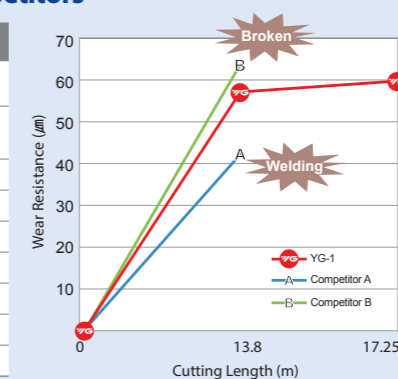

5 Flute Multiple Helix End Mills vs. Competitors

Cutting Conditions	
Milling Method	Down & Side Cutting 
Work Material	- DIN : Ti6Al4V (Titanium) - WR : 3.7165.1
Size	Ø12(R1) x Ø12 x 26 x 83
RPM	1,591 rev./min.
FEED	398 mm/min.
Axial Depth	18mm
Radial Depth	3.6mm
Coolant	Wet Cut
Machine	Machining Center

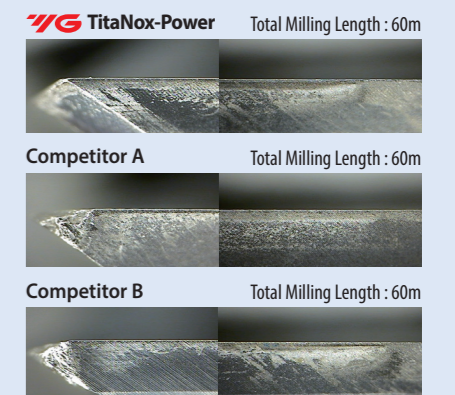
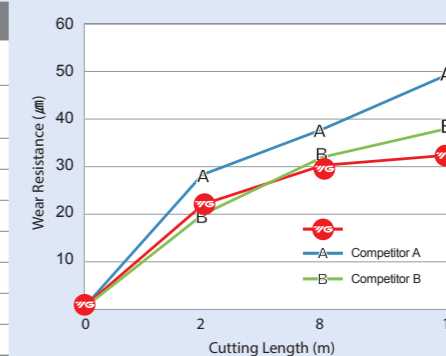

5 Flute TitaNox-Power HPC vs. Competitor

Cutting Conditions	
Milling Method	Side Cutting 
Work Material	- DIN : Ti6Al4V (Titanium) - WR : 3.7165.1
Size	Ø19.05(R0.76) x Ø19.05 x 38.1 x 101.6
RPM	2,000 rev./min.
FEED	762mm/min.
Milling Method	Axial : 1,905mm / Radial : 38.1mm
Coolant	Wet Cut
Machine	Machining Center

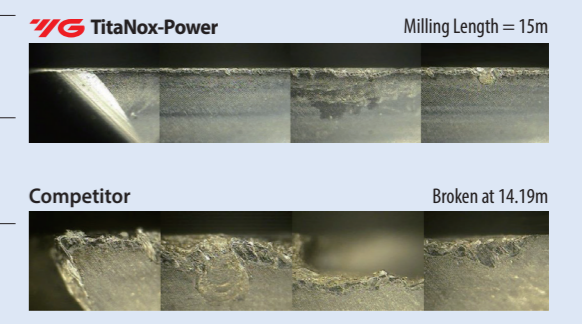
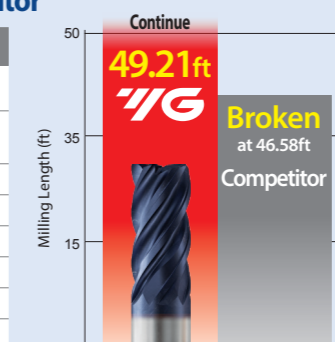

How Our 4-Flute Double-Core Design Can Cut It Where Others Can't.

Whether in profiling or slotting conditions, the TitaNox-Power double-core design takes end milling titanium and other tough metals to a new level. With our super-rigid, heat resistant design featuring an innovative large gullet configuration, the TitaNox-Power can cut it where single-core designs can't. With outstanding chip evacuation and the added ability to maneuver in tough materials, the TitaNox-Power double-core end mills can combine heavy profiling and slotting in the same move—without vibration or chip packing.

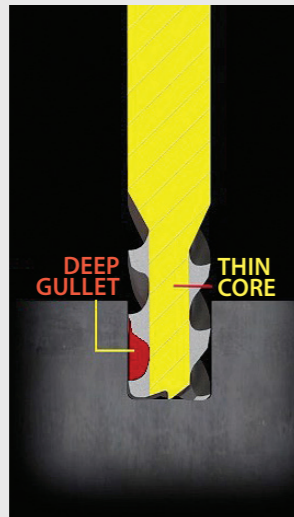

▲ Thin-core designs allow aggressive cutting at first, but are soon slowed down due to excessive vibration, and often break.

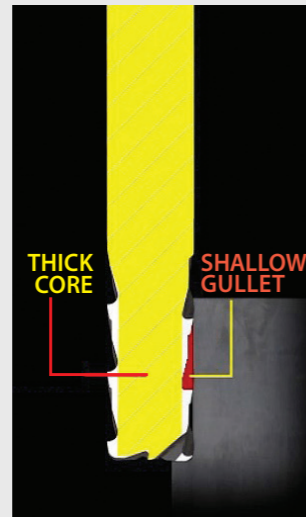

▲ Thick-core designs provide enhanced stability but don't deliver enough chip evacuation, which can often lead to catastrophic failure.

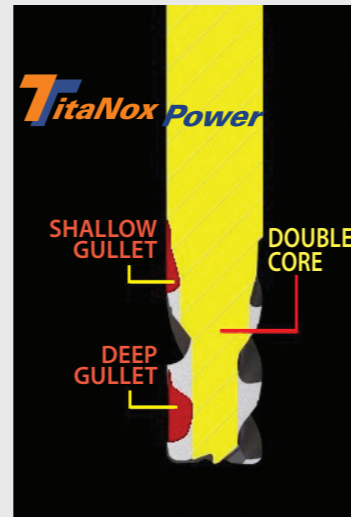

▲ The TitaNox-Power double-core design provides the best of both worlds – excellent chip evacuation combined with tool rigidity—to ensure stability, cut after cut. All this, plus quiet, vibration-free operation.

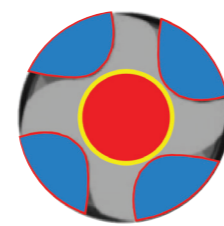
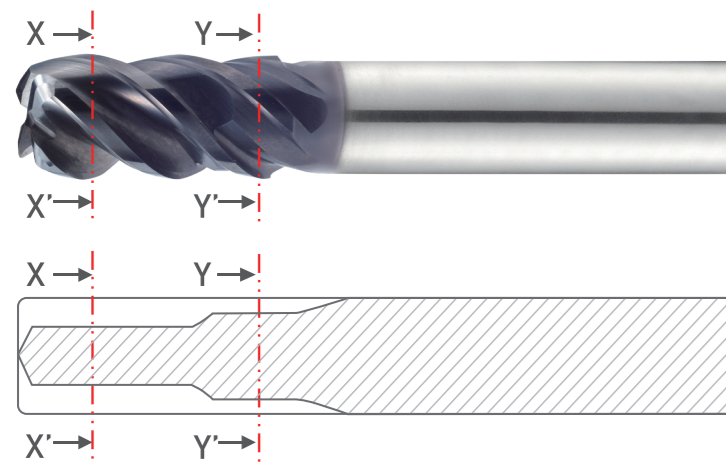

SECTION X-X'
Excellent chip evacuation

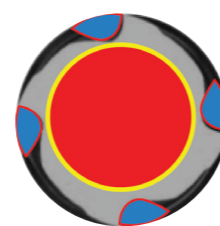

SECTION Y-Y'
Higher rigidity

▲ The illustration above detailed along the X-X' axis shows how the 4 flute design starts the cut with aggressive chip evacuation. The Y-Y' axis shows how the double core comes into play, providing perfect slotting operations through its extra-rigid double-core design.

Super-Stable, Super-Performing, Super-Productive.

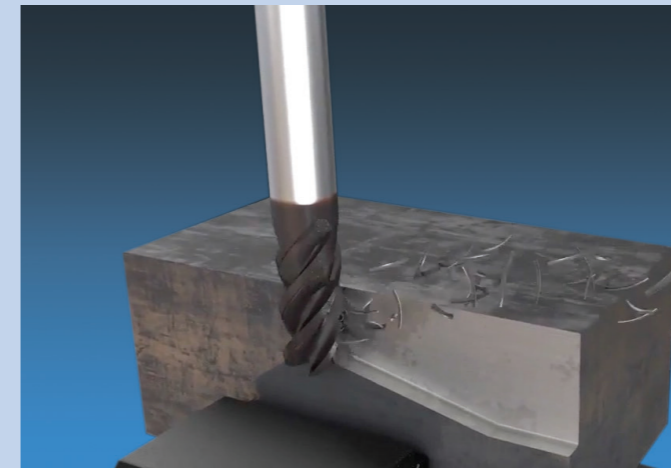

▲ For smooth, effortless profiling, the double-core design provides extremely stable cutting for increased productivity. No other end mill performs better in tough cutting conditions.

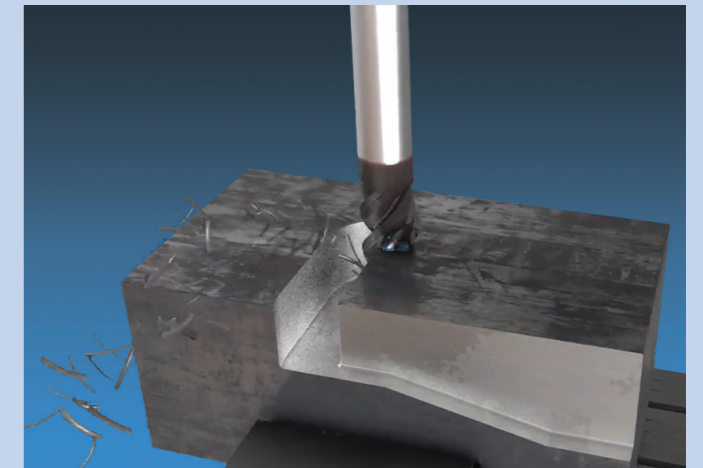

▲ Switch from profiling to slotting without excessive vibration without loading up. TitaNox-Power double-core design pushes productivity higher in tough-to-mill materials.

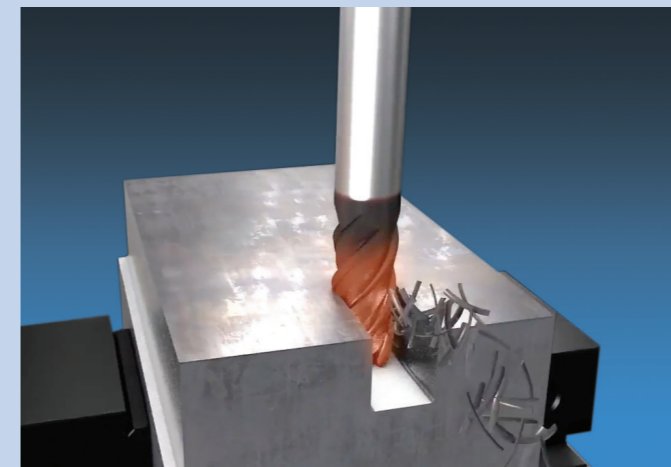

▲ Other 4 flute single-core tools can load up in heavy axial depths of cut and break, as shown in the illustration above.

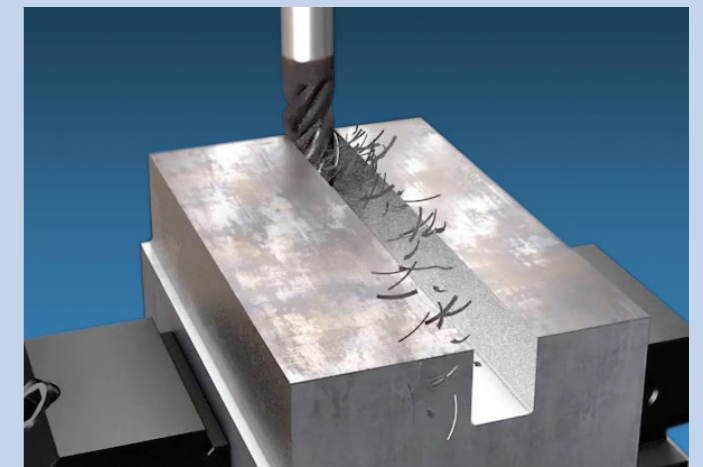

▲ The TitaNox-Power super-rigid design and large gullet configuration provide excellent chip evacuation = in titanium.

Our Advanced Coating cuts faster—and lasts longer.

Compared to other competitive coatings currently on the market, YG-1's new advanced coating brings you the best of both worlds —increased tool hardness and higher speed performance. It all adds up to increased productivity in tough materials, and longer tool life. But what really sets our advanced coating apart is how it makes the TitaNox-Power line the best value around in cutting tools — just another way YG-1 adds more value for less.



Features

- New design enhances chip space in heavy cuts, while still maintaining rigidity in peel milling.
- Full eccentric relief for edge strength.
- YG-1 advanced coating for better wear resistance
- Unequal index design for Chatter-Free cutting

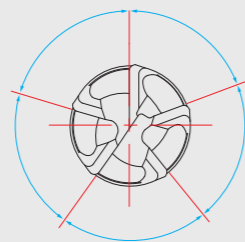

Unequal Index
Exclusively Designed Unique Geometry applied to Reduce Vibration and also to achieve Excellent surface finish

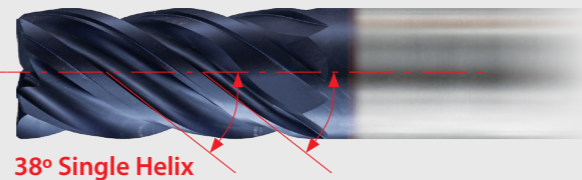

Core Design
YG-1's High Performance Core Geometries is designed for superior chip evacuation. It's excellent at Slotting & Heavy Profiling.

Applications

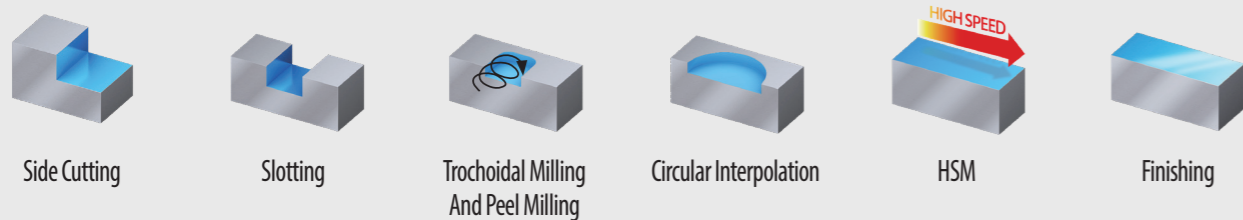

Work Materials



Recommended for high performance milling of Stainless Steel, Titanium, and Heat-Resistant Super Alloys

CASE STUDY

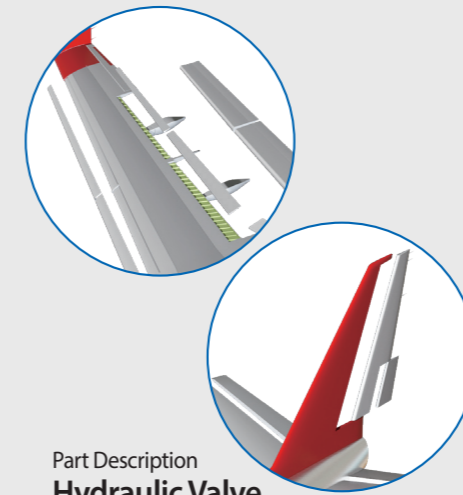

Part Description
Hydraulic Valve

Size(inch)	Ø12.7(R0.76) × Ø12.7 × 31.75 × 88.9
Work Material	15-5PH (HRc 34-42 / HB 320-400)
Tool Holder	Shrink fit
Vc	128m/min.
FEED	2,032mm/min.
RPM	3,200 rev./min.
Milling Method	Trochoidal Cutting
Ap	25.4mm
Ae	0.635mm
Coolant	Water-Based
Machine	Machining Center

14 Parts
YG
7 Parts
Competitor A

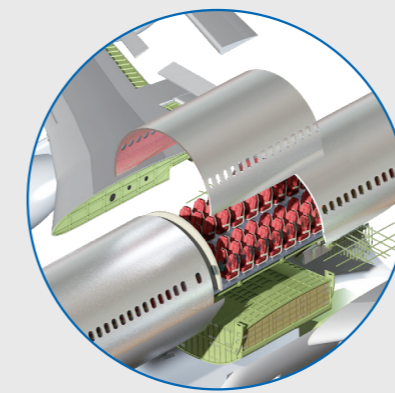

Part Description
Aerospace Structure part

Size(inch)	Ø15.875(R3.05) × Ø15.875 × 38.1(50.8) × 101.6
Work Material	Ti6Al4V (HRc 36 / HB 336)
Tool Holder	Shrink Fit
Vc	83.8 - 114.3m/min.
FEED	508 - 1,143mm/min.
RPM	1680-2292 rev./min.
Milling Method	Helical Ramping, Pocket, Ramping, Profile and Slotting
Ap	7.62 - 38.1mm
Ae	1.27 - 15.875mm
Ramping	1° - 1-1/2°
Helical Interpolation	0.5°
Coolant	Water-Based
Machine	Machining Center

6-7 Hours
YG
3-4 Hours
Competitor B

GUIDE TO ICONS

The tool is made of micrograin carbide
CARBIDE

Helix Angle
38° 43°/45° 43°/44°/45°

Tool Ends:
Square Chamfer 45° Radius R

Tool Ends:
Y Coating YG-1 Y-Coating
TiAlN Titanium Aluminum Nitride Coating
AlTiN Aluminum Titanium Nitride Coating

No. of Flutes
4 5

Type of Shank
PLAIN Plain shank
FLAT Weldon flat

Cutting Conditions

SERIES	GMG40 GMG41	GMG28 GMG29	GMG30 GMG31	GMG24 GMG25
FLUTE	4	5	5	5
HELIX ANGLE	43°/45°	43°/44°/45°	43°/44°/45°	43°/44°/45°
CUTTING EDGE SHAPE	CORNER RADIUS	CORNER RADIUS	CORNER RADIUS	SQUARE
SIZE MIN	D6.0	D6.0	D6.0	D6.0
SIZE MAX	D25.0	D25.0	D25.0	D25.0
PAGE	10	12	13	15

SOLID CARBIDE

TitaNox-Power

END MILLS

High Speed Machining for Exotic Materials:
Titanium and Stainless Steels

Please visit globalyg1.com/mat for material search

Recommended cutting conditions : p. 21-27

◎ : Excellent ○ : Good

LONG LENGTH DOUBLE CORE	SHORT LENGTH	LONG LENGTH	SHORT LENGTH
Y-Coating	Y-Coating	Y-Coating	Y-Coating



ISO	VDI 3323	Material Description	Composition / Structure / Heat Treatment	HB	HRc	GMG40	GMG28	GMG30	GMG24
P	1	Non-alloy steel	About 0.15% C Annealed	125		○	○	○	○
	2		About 0.45% C Annealed	190	13	○	○	○	○
	3		About 0.45% C Quenched & Tempered	250	25	○	○	○	○
	4		About 0.75% C Annealed	270	28	○	○	○	○
	5		About 0.75% C Quenched & Tempered	300	32	○	○	○	○
	6	Low alloy steel	Annealed	180	10	○	○	○	○
	7		Quenched & Tempered	275	29	○	○	○	○
	8		Quenched & Tempered	300	32	○	○	○	○
	9		Quenched & Tempered	350	38	○	○	○	○
	10		High alloyed steel, and tool steel	Annealed	200	15	○	○	○
	11	Quenched & Tempered		325	35	○	○	○	○
M	12	Stainless steel	Ferritic / Martensitic Annealed	200	15	◎	◎	◎	◎
	13		Martensitic Quenched & Tempered	240	23	◎	◎	◎	◎
	14		Austenitic	180	10	◎	◎	◎	◎
K	15	Grey cast iron	Pearlitic / ferritic	180	10	○	○	○	○
	16		Pearlitic (Martensitic)	260	26	○	○	○	○
	17	Nodular cast iron	Ferritic	160	3	○	○	○	○
	18		Pearlitic	250	25	○	○	○	○
	19	Malleable cast iron	Ferritic	130		○	○	○	○
20	Pearlitic		230	21	○	○	○	○	
N	21	Aluminum-wrought alloy	Not Curable	60					
	22		Curable Hardened	100					
	23	Aluminum-cast, alloyed	≤ 12% Si, Not Curable	75					
	24		≤ 12% Si, Curable Hardened	90					
	25		> 12% Si, Not Curable	130					
	26	Copper and Copper Alloys (Bronze / Brass)	Cutting Alloys, PB>1%	110					
	27		CuZn, CuSnZn (Brass)	90					
	28		CuSn, lead-free copper and electrolytic copper	100					
	29	Non Metallic Materials	Duroplastic, Fiber Reinforced Plastic						
	30		Rubber, Wood, etc.						
S	31	Heat Resistant Super Alloys	Fe Based Annealed	200	15	○	○	○	○
	32		Cured	280	30	○	○	○	○
	33		Annealed	250	25	○	○	○	○
	34		Ni or Co Based Cured	350	38	○	○	○	○
	35		Cast	320	34	○	○	○	○
	36	Titanium Alloys	Pure Titanium	400 Rm		◎	◎	◎	◎
37	Alpha + Beta Alloys Hardened		1050 Rm		◎	◎	◎	◎	
H	38	Hardened steel	Hardened	550	55				
	39		Hardened	630	60				
	40	Hardened Cast Iron	Cast	400	42				
	41		Hardened	550	55				

GMG26 GMG27	EHE54 EHE55	EMI94 EMI96	EMI93 EMI95
5	5	5	5
43°/44°/45°	40°	38°	38°
SQUARE	ROUGHING CORNER RADIUS	CORNER RADIUS	SQUARE
D6.0	D6.0	D6.0	D6.0
D25.0	D25.0	D25.0	D25.0
16	17	18	20
LONG LENGTH	-	-	-
Y-Coating	TiAlN	AlTiN	

NEW TitaNox-Power HPC



ISO	VDI 3323	Material Description	Composition / Structure / Heat Treatment	HB	HRc	GMG26	EHE54	EMI94	EMI93
P	1	Non-alloy steel	About 0.15% C Annealed	125		○	○	○	○
	2		About 0.45% C Annealed	190	13	○	○	○	○
	3		About 0.45% C Quenched & Tempered	250	25	○	○	○	○
	4		About 0.75% C Annealed	270	28	○	○	○	○
	5		About 0.75% C Quenched & Tempered	300	32	○	○	○	○
	6	Low alloy steel	Annealed	180	10	○	○	○	○
	7		Quenched & Tempered	275	29	○	○	○	○
	8		Quenched & Tempered	300	32	○	○	○	○
	9		Quenched & Tempered	350	38	○	○	○	○
	10		High alloyed steel, and tool steel	Annealed	200	15	○	○	○
	11	Quenched & Tempered		325	35	○	○	○	○
M	12	Stainless steel	Ferritic / Martensitic Annealed	200	15	◎	○	◎	◎
	13		Martensitic Quenched & Tempered	240	23	◎	○	◎	◎
	14		Austenitic	180	10	◎	○	◎	◎
K	15	Grey cast iron	Pearlitic / ferritic	180	10	○	○	○	○
	16		Pearlitic (Martensitic)	260	26	○	○	○	○
	17	Nodular cast iron	Ferritic	160	3	○	○	○	○
	18		Pearlitic	250	25	○	○	○	○
	19	Malleable cast iron	Ferritic	130		○	○	○	○
20	Pearlitic		230	21	○	○	○	○	
N	21	Aluminum-wrought alloy	Not Curable	60					
	22		Curable Hardened	100					
	23	Aluminum-cast, alloyed	≤ 12% Si, Not Curable	75					
	24		≤ 12% Si, Curable Hardened	90					
	25		> 12% Si, Not Curable	130					
	26	Copper and Copper Alloys (Bronze / Brass)	Cutting Alloys, PB>1%	110					
	27		CuZn, CuSnZn (Brass)	90					
	28		CuSn, lead-free copper and electrolytic copper	100					
	29	Non Metallic Materials	Duroplastic, Fiber Reinforced Plastic						
	30		Rubber, Wood, etc.						
S	31	Heat Resistant Super Alloys	Fe Based Annealed	200	15	○	○	○	○
	32		Cured	280	30	○	○	○	○
	33		Annealed	250	25	○	○	○	○
	34		Ni or Co Based Cured	350	38	○	○	○	○
	35		Cast	320	34	○	○	○	○
	36	Titanium Alloys	Pure Titanium	400 Rm		◎	◎	◎	◎
37	Alpha + Beta Alloys Hardened		1050 Rm		◎	◎	◎	◎	
H	38	Hardened steel	Hardened	550	55				
	39		Hardened	630	60				
	40	Hardened Cast Iron	Cast	400	42				
	41		Hardened	550	55				

Scan QR Code to See Catalogue
AEROSPACE SOLUTIONS & COMPOSITE MATERIALS



HIGH-PERFORMANCE SOLID CARBIDE END MILLS CARBIDE, 4 FLUTE CORNER RADIUS WITH DOUBLE CORE

SERIES
PLAIN SHANK **GMG40**
FLAT SHANK **GMG41**

- ▶ Double core end mill has a unique flute design for excellent chip evacuation and higher rigidity.
- ▶ The double core adds stability and aids chip flow, reducing tool deflection, improving dimensional stability and workpiece accuracy.

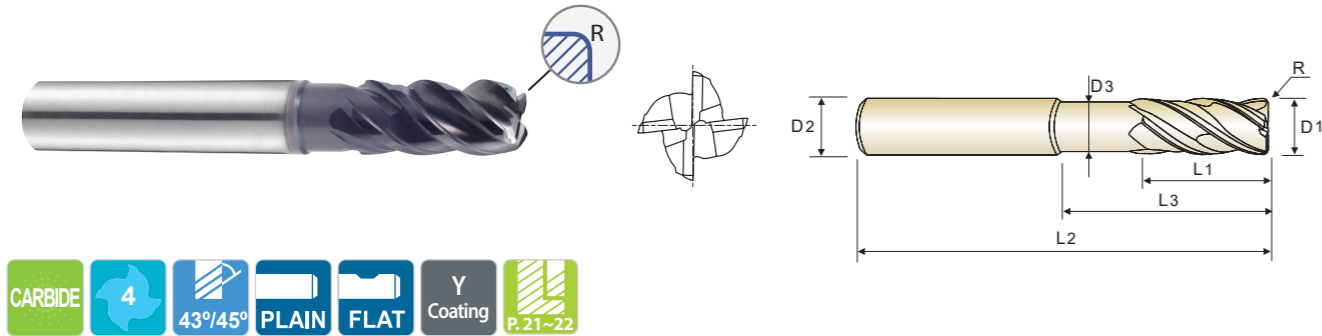

Unit : mm

EDP No.		Corner Radius	Mill Diameter	Shank Diameter	Length of Cut	Length Below Shank	Overall Length	Neck Diameter
PLAIN	FLAT	R	D1	D2	L1	L3	L2	D3
GMG40060	GMG41060	R0.5	6.0	6	13	20	57	5.5
GMG40901	GMG41901	R1.0	6.0	6	13	20	57	5.5
GMG40080	GMG41080	R0.5	8.0	8	19	25	63	7.5
GMG40902	GMG41902	R1.0	8.0	8	19	25	63	7.5
GMG40903	GMG41903	R1.5	8.0	8	19	25	63	7.5
GMG40904	GMG41904	R2.0	8.0	8	19	25	63	7.5
GMG40100	GMG41100	R0.5	10.0	10	22	30	72	9.2
GMG40905	GMG41905	R1.0	10.0	10	22	30	72	9.2
GMG40906	GMG41906	R1.5	10.0	10	22	30	72	9.2
GMG40907	GMG41907	R2.0	10.0	10	22	30	72	9.2
GMG40120	GMG41120	R0.5	12.0	12	26	35	83	11.0
GMG40908	GMG41908	R1.0	12.0	12	26	35	83	11.0
GMG40909	GMG41909	R1.5	12.0	12	26	35	83	11.0
GMG40910	GMG41910	R2.0	12.0	12	26	35	83	11.0
GMG40911	GMG41911	R3.0	12.0	12	26	35	83	11.0
GMG40140	GMG41140	R1.0	14.0	14	26	35	83	13.0
GMG40912	GMG41912	R2.0	14.0	14	26	35	83	13.0
GMG40160	GMG41160	R1.0	16.0	16	35	43	92	15.0

Mill Dia. Tolerance (mm)	Shank Dia. Tolerance
0 ~ - 0.03	h5 * Shank Dia. ≥ φ12 : h6

◆ 2 STEP CORE

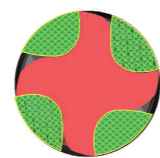
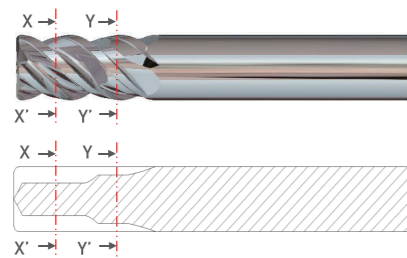

<SECTION X-X'>
Excellent chip evacuation



<SECTION Y-Y'>
Higher rigidity

◎ : Excellent ○ : Good

ISO Material Description	P										M				K					
	Non-alloy steel					Low alloy steel					High alloyed steel, and tool steel		Stainless steel		Grey cast iron		Nodular cast iron		Malleable cast iron	
VDI 3323	1	2	3	4	5	6	7	8	9	10	11	12	13	14	15	16	17	18	19	20
HRc		13	25	28	32	10	29	32	38	15	35	15	23	10	10	26	3	25	3	21
HB	125	190	250	270	300	180	275	300	350	200	325	200	240	180	180	260	160	250	130	230
Recommend	○	○	○	○	○	○	○	○	○	○	○	◎	◎	◎	○	○	○	○	○	○

ISO Material Description	N										S						H				
	Aluminum-wrought alloy		Aluminum-cast, alloyed		Copper and Copper Alloys (Bronze / Brass)		Non Metallic Materials		Heat Resistant Super Alloys				Titanium Alloys		Hardened steel	Chilled Cast Iron	Hardened Cast Iron				
VDI 3323	21	22	23	24	25	26	27	28	29	30	31	32	33	34	35	36	37	38	39	40	41
HRc						15	30	25	38	34	15	30	25	38	34	55	60	42	42	55	
HB	60	100	75	90	130	110	90	100			200	280	250	350	320	400 Rm	1050 Rm	550	630	400	550
Recommend						○	○	○	○	○	○	○	○	○	○	◎	◎	○	○	○	○

HIGH-PERFORMANCE SOLID CARBIDE END MILLS CARBIDE, 4 FLUTE CORNER RADIUS WITH DOUBLE CORE

SERIES
PLAIN SHANK **GMG40**
FLAT SHANK **GMG41**

- ▶ Double core end mill has a unique flute design for excellent chip evacuation and higher rigidity.
- ▶ The double core adds stability and aids chip flow, reducing tool deflection, improving dimensional stability and workpiece accuracy.

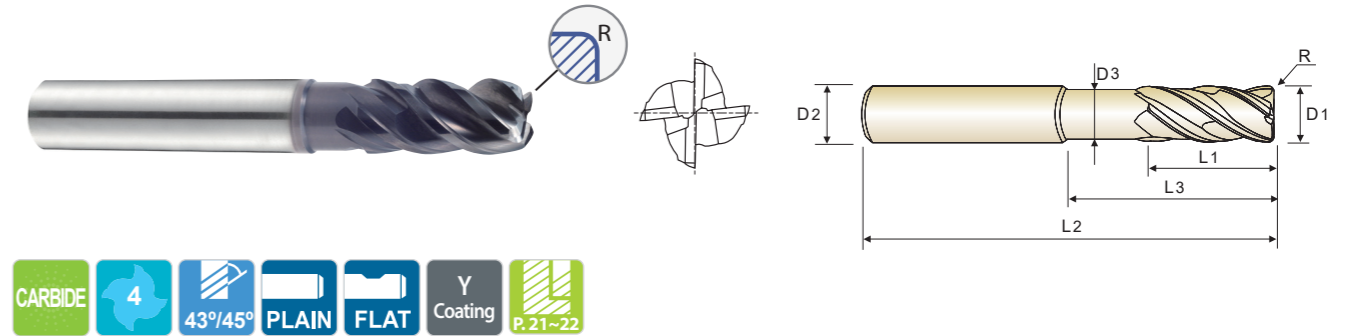

Unit : mm

EDP No.		Corner Radius	Mill Diameter	Shank Diameter	Length of Cut	Length Below Shank	Overall Length	Neck Diameter
PLAIN	FLAT	R	D1	D2	L1	L3	L2	D3
GMG40913	GMG41913	R1.5	16.0	16	35	43	92	15.0
GMG40914	GMG41914	R2.0	16.0	16	35	43	92	15.0
GMG40915	GMG41915	R3.0	16.0	16	35	43	92	15.0
GMG40916	GMG41916	R4.0	16.0	16	35	43	92	15.0
GMG40200	GMG41200	R1.0	20.0	20	44	56	110	19.0
GMG40917	GMG41917	R1.5	20.0	20	44	56	110	19.0
GMG40918	GMG41918	R2.0	20.0	20	44	56	110	19.0
GMG40919	GMG41919	R3.0	20.0	20	44	56	110	19.0
GMG40920	GMG41920	R3.5	20.0	20	44	56	110	19.0
GMG40921	GMG41921	R4.0	20.0	20	44	56	110	19.0
GMG40250	GMG41250	R1.0	25.0	25	55	70	130	24.0
GMG40922	GMG41922	R1.5	25.0	25	55	70	130	24.0
GMG40923	GMG41923	R2.0	25.0	25	55	70	130	24.0
GMG40924	GMG41924	R3.0	25.0	25	55	70	130	24.0
GMG40925	GMG41925	R4.0	25.0	25	55	70	130	24.0

Mill Dia. Tolerance (mm)	Shank Dia. Tolerance
0 ~ - 0.03	h5 * Shank Dia. ≥ φ12 : h6

◆ 2 STEP CORE

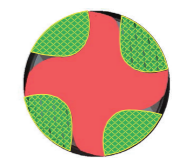
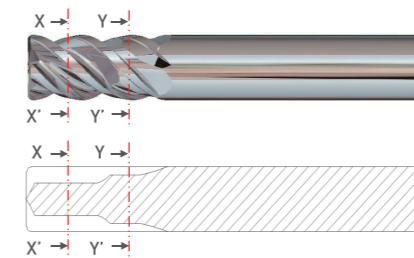

<SECTION X-X'>
Excellent chip evacuation

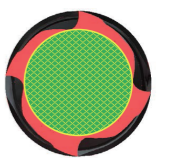

<SECTION Y-Y'>
Higher rigidity

◎ : Excellent ○ : Good

ISO Material Description	P										M				K					
	Non-alloy steel					Low alloy steel					High alloyed steel, and tool steel		Stainless steel		Grey cast iron		Nodular cast iron		Malleable cast iron	
VDI 3323	1	2	3	4	5	6	7	8	9	10	11	12	13	14	15	16	17	18	19	20
HRc		13	25	28	32	10	29	32	38	15	35	15	23	10	10	26	3	25	3	21
HB	125	190	250	270	300	180	275	300	350	200	325	200	240	180	180	260	160	250	130	230
Recommend	○	○	○	○	○	○	○	○	○	○	○	◎	◎	◎	○	○	○	○	○	○

ISO Material Description	N										S						H				
	Aluminum-wrought alloy		Aluminum-cast, alloyed		Copper and Copper Alloys (Bronze / Brass)		Non Metallic Materials		Heat Resistant Super Alloys				Titanium Alloys		Hardened steel	Chilled Cast Iron	Hardened Cast Iron				
VDI 3323	21	22	23	24	25	26	27	28	29	30	31	32	33	34	35	36	37	38	39	40	41
HRc						15	30	25	38	34	15	30	25	38	34	55	60	42	42	55	
HB	60	100	75	90	130	110	90	100			200	280	250	350	320	400 Rm	1050 Rm	550	630	400	550
Recommend						○	○	○	○	○	○	○	○	○	○	◎	◎	○	○	○	○

HIGH-PERFORMANCE SOLID CARBIDE END MILLS
CARBIDE, 5 FLUTE CORNER RADIUS SHORT LENGTH

SERIES
PLAIN SHANK **GMG28**
FLAT SHANK **GMG29**

- ▶ Excellent performance results and long tool life when machining Titanium and other tough materials.
- ▶ This tool has high rigidity of flute so that is possible to use for heavy profile and high speed milling.
- ▶ For protecting Corner chipping of end teeth, Corner Radius & Chamfer are adopted.

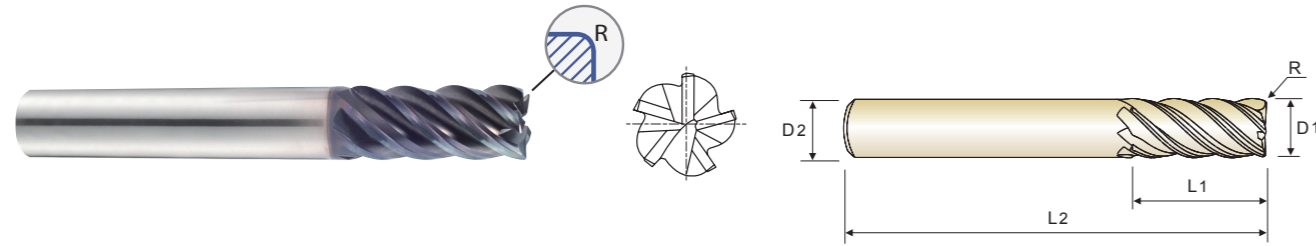

Unit : mm

EDP No.		Corner Radius	Mill Diameter	Shank Diameter	Length of Cut	Overall Length
PLAIN	FLAT	R	D1	D2	L1	L2
GMG28060	GMG29060	R0.5	6.0	6	10	54
GMG28080	GMG29080	R0.5	8.0	8	12	58
GMG28100	GMG29100	R0.5	10.0	10	14	66
GMG28120	GMG29120	R0.5	12.0	12	16	73
GMG28160	GMG29160	R1.0	16.0	16	22	82
GMG28200	GMG29200	R1.0	20.0	20	26	92
GMG28250	GMG29250	R1.0	25.0	25	29	100

Mill Dia. Tolerance (mm)	Shank Dia. Tolerance
0 ~ - 0.03	h5 * Shank Dia. ≥ Ø12 : h6

HIGH-PERFORMANCE SOLID CARBIDE END MILLS
CARBIDE, 5 FLUTE CORNER RADIUS LONG LENGTH

SERIES
PLAIN SHANK **GMG30**
FLAT SHANK **GMG31**

- ▶ Excellent performance results and long tool life when machining Titanium and other tough materials.
- ▶ This tool has high rigidity of flute so that is possible to use for heavy profile and high speed milling.
- ▶ For protecting Corner chipping of end teeth, Corner Radius & Chamfer are adopted.

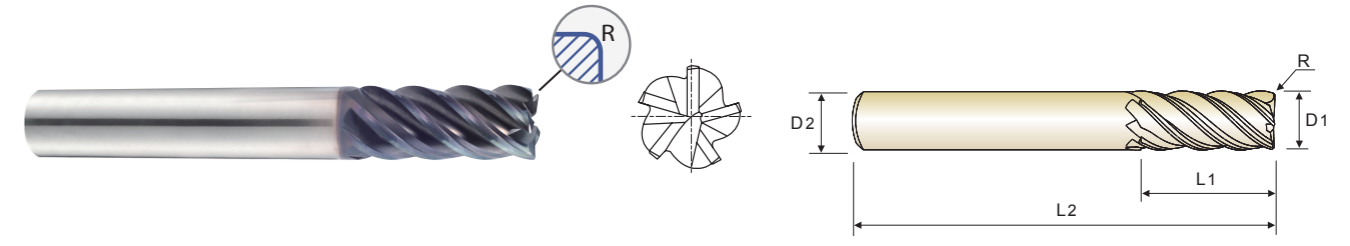

Unit : mm

EDP No.		Corner Radius	Mill Diameter	Shank Diameter	Length of Cut	Overall Length
PLAIN	FLAT	R	D1	D2	L1	L2
GMG30060	GMG31060	R0.3	6.0	6	13	57
GMG30901	GMG31901	R0.5	6.0	6	13	57
GMG30902	GMG31902	R1.0	6.0	6	13	57
GMG30080	GMG31080	R0.5	8.0	8	19	63
GMG30903	GMG31903	R1.0	8.0	8	19	63
GMG30904	GMG31904	R1.5	8.0	8	19	63
GMG30905	GMG31905	R2.0	8.0	8	19	63
GMG30100	GMG31100	R0.5	10.0	10	22	72
GMG30906	GMG31906	R1.0	10.0	10	22	72
GMG30907	GMG31907	R1.5	10.0	10	22	72
GMG30908	GMG31908	R2.0	10.0	10	22	72
GMG30120	GMG31120	R0.5	12.0	12	26	83
GMG30909	GMG31909	R1.0	12.0	12	26	83
GMG30910	GMG31910	R1.5	12.0	12	26	83
GMG30911	GMG31911	R2.0	12.0	12	26	83
GMG30912	GMG31912	R2.5	12.0	12	26	83
GMG30913	GMG31913	R3.0	12.0	12	26	83
GMG30160	GMG31160	R1.0	16.0	16	36	92
GMG30914	GMG31914	R1.5	16.0	16	36	92
GMG30915	GMG31915	R2.0	16.0	16	36	92
GMG30916	GMG31916	R2.5	16.0	16	36	92
GMG30917	GMG31917	R3.0	16.0	16	36	92

Mill Dia. Tolerance (mm)	Shank Dia. Tolerance
0 ~ - 0.03	h5 * Shank Dia. ≥ Ø12 : h6

NEXT PAGE ▶

◎ : Excellent ○ : Good

ISO Material Description	P										M				K						
	Non-alloy steel					Low alloy steel					High alloyed steel, and tool steel				Stainless steel		Grey cast iron		Nodular cast iron		Malleable cast iron
VDI 3323	1	2	3	4	5	6	7	8	9	10	11	12	13	14	15	16	17	18	19	20	
HRc	13	25	28	32	38	10	29	32	38	15	35	15	23	10	10	26	3	25	21	21	
HB	125	190	250	270	300	180	275	300	350	200	325	200	240	180	180	260	160	250	130	230	
Recommend	○	○	○	○	○	○	○	○	○	○	○	◎	◎	◎	○	○	○	○	○	○	○

ISO Material Description	N										S						H					
	Aluminum-wrought alloy		Aluminum-cast, alloyed			Copper and Copper Alloys (Bronze / Brass)		Non Metallic Materials			Heat Resistant Super Alloys			Titanium Alloys			Hardened steel	Chilled Cast Iron	Hardened Cast Iron			
VDI 3323	21	22	23	24	25	26	27	28	29	30	31	32	33	34	35	36	37	38	39	40	41	
HRc	15	30	25	38	34	15	30	25	38	34	15	30	25	38	34	400 Rm	1050 Rm	550	630	400	550	
HB	60	100	75	90	130	110	90	100			200	280	250	350	320	400 Rm	1050 Rm	550	630	400	550	
Recommend	○	○	○	○	○	○	○	○	○	○	○	○	○	○	○	◎	◎	○	○	○	○	○

◎ : Excellent ○ : Good

ISO Material Description	P										M				K						
	Non-alloy steel					Low alloy steel					High alloyed steel, and tool steel				Stainless steel		Grey cast iron		Nodular cast iron		Malleable cast iron
VDI 3323	1	2	3	4	5	6	7	8	9	10	11	12	13	14	15	16	17	18	19	20	
HRc	13	25	28	32	38	10	29	32	38	15	35	15	23	10	10	26	3	25	21	21	
HB	125	190	250	270	300	180	275	300	350	200	325	200	240	180	180	260	160	250	130	230	
Recommend	○	○	○	○	○	○	○	○	○	○	○	◎	◎	◎	○	○	○	○	○	○	○

ISO Material Description	N										S						H					
	Aluminum-wrought alloy		Aluminum-cast, alloyed			Copper and Copper Alloys (Bronze / Brass)		Non Metallic Materials			Heat Resistant Super Alloys			Titanium Alloys			Hardened steel	Chilled Cast Iron	Hardened Cast Iron			
VDI 3323	21	22	23	24	25	26	27	28	29	30	31	32	33	34	35	36	37	38	39	40	41	
HRc	15	30	25	38	34	15	30	25	38	34	15	30	25	38	34	400 Rm	1050 Rm	550	630	400	550	
HB	60	100	75	90	130	110	90	100			200	280	250	350	320	400 Rm	1050 Rm	550	630	400	550	
Recommend	○	○	○	○	○	○	○	○	○	○	○	○	○	○	○	◎	◎	○	○	○	○	○

HIGH-PERFORMANCE SOLID CARBIDE END MILLS
CARBIDE, 5 FLUTE CORNER RADIUS LONG LENGTH

SERIES
PLAIN SHANK **GMG30**
FLAT SHANK **GMG31**

- ▶ Excellent performance results and long tool life when machining Titanium and other tough materials.
- ▶ This tool has high rigidity of flute so that is possible to use for heavy profile and high speed milling.
- ▶ For protecting Corner chipping of end teeth, Corner Radius & Chamfer are adopted.

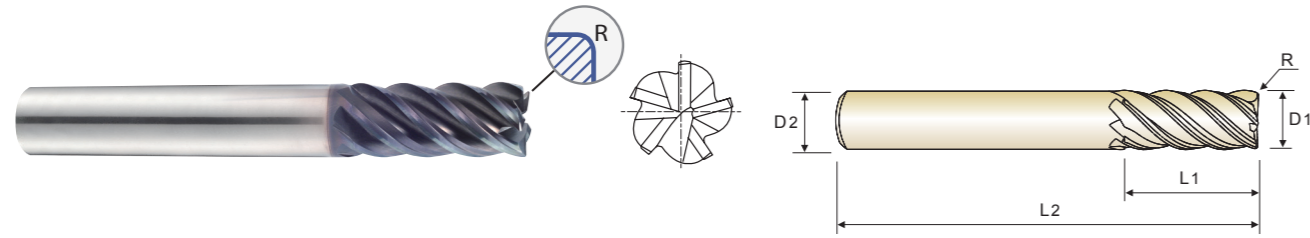

Unit : mm

EDP No.		Corner Radius	Mill Diameter	Shank Diameter	Length of Cut	Overall Length
PLAIN	FLAT	R	D1	D2	L1	L2
GMG30918	GMG31918	R4.0	16.0	16	36	92
GMG30200	GMG31200	R1.0	20.0	20	44	104
GMG30919	GMG31919	R1.5	20.0	20	44	104
GMG30920	GMG31920	R2.0	20.0	20	44	104
GMG30921	GMG31921	R2.5	20.0	20	44	104
GMG30922	GMG31922	R3.0	20.0	20	44	104
GMG30923	GMG31923	R4.0	20.0	20	44	104
GMG30924	GMG31924	R5.0	20.0	20	44	104
GMG30250	GMG31250	R1.0	25.0	25	54	121
GMG30925	GMG31925	R1.5	25.0	25	54	121
GMG30926	GMG31926	R2.0	25.0	25	54	121
GMG30927	GMG31927	R2.5	25.0	25	54	121
GMG30928	GMG31928	R3.0	25.0	25	54	121
GMG30929	GMG31929	R4.0	25.0	25	54	121
GMG30930	GMG31930	R5.0	25.0	25	54	121

Mill Dia. Tolerance (mm)	Shank Dia. Tolerance
0 ~ - 0.03	h5 * Shank Dia. ≥ Ø12 : h6

◎ : Excellent ○ : Good

ISO Material Description	P										M				K																										
	Non-alloy steel					Low alloy steel					High alloyed steel, and tool steel				Stainless steel		Grey cast iron		Nodular cast iron		Malleable cast iron																				
VDI 3323	1	2	3	4	5	6	7	8	9	10	11	12	13	14	15	16	17	18	19	20	21	22	23	24	25	26	27	28	29	30	31	32	33	34	35	36	37	38	39	40	41
HRc	13	25	28	32	38	10	29	32	38	15	35	15	23	10	10	26	3	25	15	21	15	30	25	38	34	200	280	250	350	320	400 Rm	1050 Rm	550	630	400	550					
HB	125	190	250	270	300	180	275	300	350	200	325	200	240	180	180	260	160	250	130	230	180	260	160	250	130	230															
Recommend	○	○	○	○	○	○	○	○	○	○	○	◎	◎	◎	○	○	○	○	○	○	○	○	○	○	○	○	○	○	○	○	○	○	○	○	○	○	○	○	○	○	○

ISO Material Description	N					S										H					
	Aluminum-wrought alloy		Aluminum-cast, alloyed			Copper and Copper Alloys (Bronze / Brass)			Non Metallic Materials		Heat Resistant Super Alloys					Titanium Alloys		Hardened steel	Chilled Cast Iron	Hardened Cast Iron	
VDI 3323	21	22	23	24	25	26	27	28	29	30	31	32	33	34	35	36	37	38	39	40	41
HRc	60	100	75	90	130	110	90	100			200	280	250	350	320	400 Rm	1050 Rm	550	630	400	550
HB	60	100	75	90	130	110	90	100			200	280	250	350	320	400 Rm	1050 Rm	550	630	400	550
Recommend	○	○	○	○	○	○	○	○	○	○	○	○	○	○	○	○	○	○	○	○	○

HIGH-PERFORMANCE SOLID CARBIDE END MILLS
CARBIDE, 5 FLUTE SHORT LENGTH

SERIES
PLAIN SHANK **GMG24**
FLAT SHANK **GMG25**

- ▶ Excellent performance results and long tool life when machining Titanium and other tough materials.
- ▶ This tool has high rigidity of flute so that is possible to use for heavy profile and high speed milling.
- ▶ For protecting Corner chipping of end teeth, Corner Radius & Chamfer are adopted.

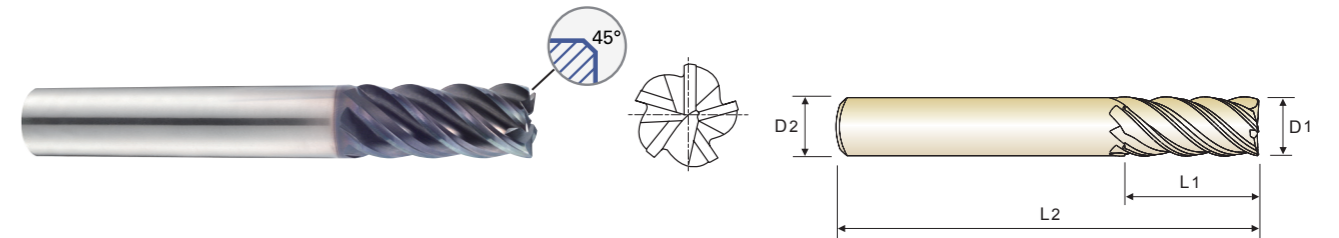

Unit : mm

EDP No.		Mill Diameter	Shank Diameter	Length of Cut	Overall Length	Chamfer
PLAIN	FLAT	D1	D2	L1	L2	
GMG24060	GMG25060	6.0	6	10	54	0.20
GMG24080	GMG25080	8.0	8	12	58	0.20
GMG24100	GMG25100	10.0	10	14	66	0.30
GMG24120	GMG25120	12.0	12	16	73	0.35
GMG24160	GMG25160	16.0	16	22	82	0.40
GMG24200	GMG25200	20.0	20	26	92	0.50
GMG24250	GMG25250	25.0	25	29	100	0.50

Mill Dia. Tolerance (mm)	Shank Dia. Tolerance
0 ~ - 0.03	h5 * Shank Dia. ≥ Ø12 : h6

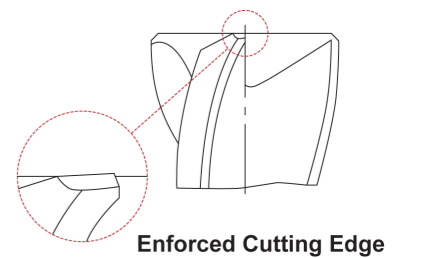

◎ : Excellent ○ : Good

ISO Material Description	P										M				K																										
	Non-alloy steel					Low alloy steel					High alloyed steel, and tool steel				Stainless steel		Grey cast iron		Nodular cast iron		Malleable cast iron																				
VDI 3323	1	2	3	4	5	6	7	8	9	10	11	12	13	14	15	16	17	18	19	20	21	22	23	24	25	26	27	28	29	30	31	32	33	34	35	36	37	38	39	40	41
HRc	13	25	28	32	38	10	29	32	38	15	35	15	23	10	10	26	3	25	15	21	15	30	25	38	34	200	280	250	350	320	400 Rm	1050 Rm	550	630	400	550					
HB	125	190	250	270	300	180	275	300	350	200	325	200	240	180	180	260	160	250	130	230	180	260	160	250	130	230															
Recommend	○	○	○	○	○	○	○	○	○	○	○	◎	◎	◎	○	○	○	○	○	○	○	○	○	○	○	○	○	○	○	○	○	○	○	○	○	○	○	○	○	○	○

ISO Material Description	N					S										H					
	Aluminum-wrought alloy		Aluminum-cast, alloyed			Copper and Copper Alloys (Bronze / Brass)			Non Metallic Materials		Heat Resistant Super Alloys					Titanium Alloys		Hardened steel	Chilled Cast Iron	Hardened Cast Iron	
VDI 3323	21	22	23	24	25	26	27	28	29	30	31	32	33	34	35	36	37	38	39	40	41
HRc	60	100	75	90	130	110	90	100			200	280	250	350	320	400 Rm	1050 Rm	550	630	400	550
HB	60	100	75	90	130	110	90	100			200	280	250	350	320	400 Rm	1050 Rm	550	630	400	550
Recommend	○	○	○	○	○	○	○	○	○	○	○	○	○	○	○	○	○	○	○	○	○

HIGH-PERFORMANCE SOLID CARBIDE END MILLS CARBIDE, 5 FLUTE LONG LENGTH

SERIES
PLAIN SHANK **GMG26**
FLAT SHANK **GMG27**

- ▶ Suitable for Titanium, Titanium Alloys, Inconel and Stainless Steels.
- ▶ Optimized flute design for chip evacuation and rigidity when machining difficult-to-cut materials.
- ▶ Special roughing profile for machining Titanium and Titanium Alloys.
- ▶ Longer tool life with special coating.

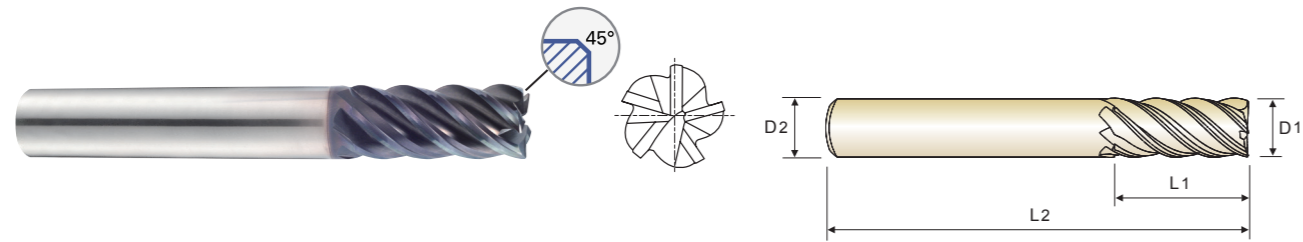

EDP No.		Mill Diameter	Shank Diameter	Length of Cut	Overall Length	Chamfer
PLAIN	FLAT	D1	D2	L1	L2	
GMG26060	GMG27060	6.0	6	13	57	0.20
GMG26080	GMG27080	8.0	8	19	63	0.20
GMG26100	GMG27100	10.0	10	22	72	0.30
GMG26120	GMG27120	12.0	12	26	83	0.35
GMG26160	GMG27160	16.0	16	36	92	0.40
GMG26200	GMG27200	20.0	20	44	104	0.50
GMG26250	GMG27250	25.0	25	54	121	0.50

Unit : mm

Mill Dia. Tolerance (mm)	Shank Dia. Tolerance
0 ~ - 0.03	h5 * Shank Dia. ≥ φ12 : h6

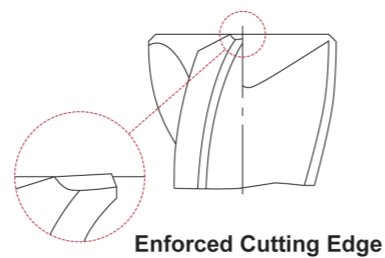

ISO Material Description	P										M				K						
	Non-alloy steel					Low alloy steel					High alloyed steel, and tool steel				Stainless steel		Grey cast iron		Nodular cast iron		Malleable cast iron
VDI 3323	1	2	3	4	5	6	7	8	9	10	11	12	13	14	15	16	17	18	19	20	
HRC	13	25	28	32	10	29	32	38	15	35	15	23	10	10	26	3	25				
HB	125	190	250	270	300	180	275	300	350	200	325	200	240	180	180	260	160	250	130	230	
Recommend	○	○	○	○	○	○	○	○	○	○	○	○	○	○	○	○	○	○	○	○	○

ISO Material Description	N					S							H									
	Aluminum-wrought alloy		Aluminum-cast, alloyed		Copper and Copper Alloys (Bronze / Brass)	Heat Resistant Super Alloys				Titanium Alloys			Hardened steel	Chilled Cast Iron	Hardened Cast Iron							
VDI 3323	21	22	23	24	25	26	27	28	29	30	31	32	33	34	35	36	37	38	39	40	41	
HRC						15	30	25	38	34	15	30	25	38	34	55	60	42	55			
HB	60	100	75	90	130	110	90	100			200	280	250	350	320	400 Rm	1050 Rm	550	630	400	550	
Recommend						○	○	○	○	○	○	○	○	○	○	◎	◎	○	○	○	○	○

◎ : Excellent ○ : Good

HIGH-PERFORMANCE SOLID CARBIDE END MILLS CARBIDE, 5 FLUTE 40° HELIX CORNER RADIUS ROUGHING - FINE

SERIES
PLAIN SHANK **EHE54**
FLAT SHANK **EHE55**

- ▶ Excellent performance results and long tool life when machining Titanium and other tough materials.
- ▶ This tool has high rigidity of flute so that is possible to use for heavy profile and high speed milling.
- ▶ For protecting Corner chipping of end teeth, Corner Radius & Chamfer are adopted.

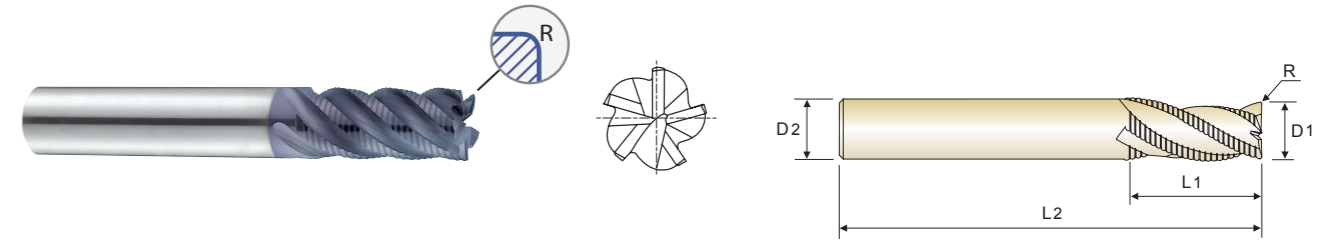

EDP No.		Corner Radius	Mill Diameter	Shank Diameter	Length of Cut	Overall Length
PLAIN	FLAT	R	D1 (h10)	D2 (h6)	L1	L2
EHE54060	EHE55060	R0.2	6.0	6	16	57
EHE54080	EHE55080	R0.2	8.0	8	16	63
EHE54100	EHE55100	R0.3	10.0	10	22	72
EHE54120	EHE55120	R0.3	12.0	12	26	83
EHE54140	EHE55140	R0.3	14.0	14	26	83
EHE54160	EHE55160	R0.3	16.0	16	32	92
EHE54200	EHE55200	R0.3	20.0	20	38	104
EHE54250	EHE55250	R0.3	25.0	25	45	121

Unit : mm

Tolerances according to DIN 7160 & 7161

	Tolerance range in μm				
	Nominal-Diameter in mm				
	from 1 to 3	over 3 to 6	over 6 to 10	over 10 to 18	over 18 to 30
h10	0 - 40	0 - 48	0 - 58	0 - 70	0 - 84
h5	0 - 4	0 - 5	0 - 6	0 - 8	0 - 9

* Shank Dia. ≥ φ12 : h6

ISO Material Description	P										M				K						
	Non-alloy steel					Low alloy steel					High alloyed steel, and tool steel				Stainless steel		Grey cast iron		Nodular cast iron		Malleable cast iron
VDI 3323	1	2	3	4	5	6	7	8	9	10	11	12	13	14	15	16	17	18	19	20	
HRC	13	25	28	32	10	29	32	38	15	35	15	23	10	10	26	3	25				
HB	125	190	250	270	300	180	275	300	350	200	325	200	240	180	180	260	160	250	130	230	
Recommend						○	○	○	○	○	○	○	○	○	○	○	○	○	○	○	○

ISO Material Description	N					S							H									
	Aluminum-wrought alloy		Aluminum-cast, alloyed		Copper and Copper Alloys (Bronze / Brass)	Heat Resistant Super Alloys				Titanium Alloys			Hardened steel	Chilled Cast Iron	Hardened Cast Iron							
VDI 3323	21	22	23	24	25	26	27	28	29	30	31	32	33	34	35	36	37	38	39	40	41	
HRC						15	30	25	38	34	15	30	25	38	34	55	60	42	55			
HB	60	100	75	90	130	110	90	100			200	280	250	350	320	400 Rm	1050 Rm	550	630	400	550	
Recommend						○	○	○	○	○	○	○	○	○	○	◎	◎	○	○	○	○	○

◎ : Excellent ○ : Good

HIGH PERFORMANCE SOLID CARBIDE END MILLS - TitaNox-Power HPC
5-FLUTE STANDARD LENGTH

NEW SERIES
 PLAIN SHANK **EMI94**
 FLAT SHANK **EMI96**

- ▶ New design enhances chip space in heavy cuts, while still maintaining rigidity in peel milling.
- ▶ Unequal index design for Chatter-Free cutting
- ▶ high performance milling of Stainless Steel, Titanium, and Heat-Resistant Super Alloys



* (NEW SIZE) Unit : mm

EDP No.		Corner Radius	Mill Diameter	Shank Diameter	Length of Cut	Overall Length
PLAIN	FLAT	R	D ₁	D ₂	L ₁	L ₂
EMI94060	EMI96060	R0.3	6.0	6	13	57
EMI94901	EMI96901	R0.5	6.0	6	13	57
EMI94902	EMI96902	R1.0	6.0	6	13	57
EMI94080	EMI96080	R0.5	8.0	8	19	63
EMI94903	EMI96903	R1.0	8.0	8	19	63
EMI94904	EMI96904	R1.5	8.0	8	19	63
EMI94905	EMI96905	R2.0	8.0	8	19	63
EMI94100	EMI96100	R0.5	10.0	10	22	72
EMI94906	EMI96906	R1.0	10.0	10	22	72
EMI94907	EMI96907	R1.5	10.0	10	22	72
EMI94908	EMI96908	R2.0	10.0	10	22	72
* EMI94909	EMI96909	R2.5	10.0	10	22	72
EMI94120	EMI96120	R0.5	12.0	12	26	83
EMI94910	EMI96910	R1.0	12.0	12	26	83
EMI94911	EMI96911	R1.5	12.0	12	26	83
EMI94912	EMI96912	R2.0	12.0	12	26	83
EMI94913	EMI96913	R2.5	12.0	12	26	83
EMI94914	EMI96914	R3.0	12.0	12	26	83
* EMI94160	EMI96160	R0.5	16.0	16	36	92
EMI94915	EMI96915	R1.0	16.0	16	36	92
EMI94916	EMI96916	R1.5	16.0	16	36	92
EMI94917	EMI96917	R2.0	16.0	16	36	92
EMI94918	EMI96918	R2.5	16.0	16	36	92

NEXT PAGE ▶

◎ : Excellent ○ : Good

ISO	P										M				K						
	Non-alloy steel					Low alloy steel					High alloyed steel, and tool steel				Stainless steel		Grey cast iron		Nodular cast iron		Malleable cast iron
VDI 3323	1	2	3	4	5	6	7	8	9	10	11	12	13	14	15	16	17	18	19	20	
HRc	13	25	28	32	32	10	29	32	38	15	35	15	23	10	10	26	3	25	19	21	
HB	125	190	250	270	300	180	275	300	350	200	325	200	240	180	180	260	160	250	130	230	
Recommend	○	○	○	○	○	○	○	○	○	○	○	◎	◎	◎	○	○	○	○	○	○	○

ISO	N					S										H						
	Aluminum-wrought alloy		Aluminum-cast, alloyed			Copper and Copper Alloys (Bronze / Brass)		Non Metallic Materials			Heat Resistant Super Alloys					Titanium Alloys		Hardened steel	Chilled Cast Iron	Hardened Cast Iron		
VDI 3323	21	22	23	24	25	26	27	28	29	30	31	32	33	34	35	36	37	38	39	40	41	
HRc						15	30	25	38	34							55	60	42	55		
HB	60	100	75	90	130	110	90	100			200	280	250	350	320	400 Rm	1050 Rm	550	630	400	550	
Recommend						○	○	○	○	○	○	○	○	○	○	◎	◎	○	○	○	○	○

HIGH PERFORMANCE SOLID CARBIDE END MILLS - TitaNox-Power HPC
5-FLUTE STANDARD LENGTH

NEW SERIES
 PLAIN SHANK **EMI94**
 FLAT SHANK **EMI96**

- ▶ New design enhances chip space in heavy cuts, while still maintaining rigidity in peel milling.
- ▶ Unequal index design for Chatter-Free cutting
- ▶ high performance milling of Stainless Steel, Titanium, and Heat-Resistant Super Alloys

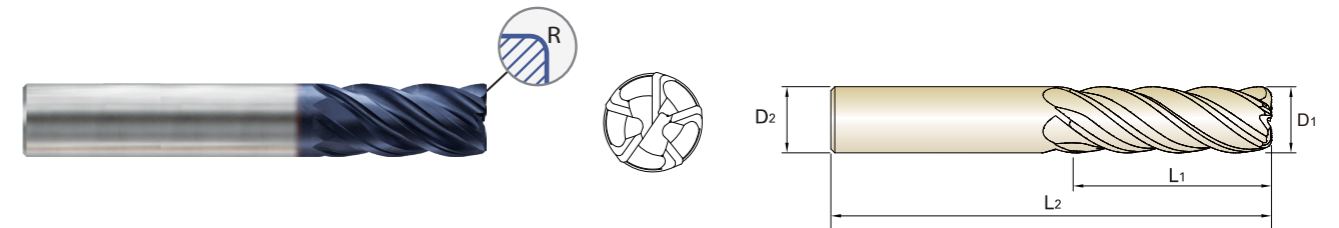

Unit : mm

EDP No.		Corner Radius	Mill Diameter	Shank Diameter	Length of Cut	Overall Length
PLAIN	FLAT	R	D ₁	D ₂	L ₁	L ₂
EMI94919	EMI96919	R3.0	16.0	16	36	92
EMI94920	EMI96920	R4.0	16.0	16	36	92
EMI94200	EMI96200	R1.0	20.0	20	44	104
EMI94921	EMI96921	R1.5	20.0	20	44	104
EMI94922	EMI96922	R2.0	20.0	20	44	104
EMI94923	EMI96923	R2.5	20.0	20	44	104
EMI94924	EMI96924	R3.0	20.0	20	44	104
EMI94925	EMI96925	R4.0	20.0	20	44	104
EMI94926	EMI96926	R5.0	20.0	20	44	104
EMI94250	EMI96250	R1.0	25.0	25	54	121
EMI94927	EMI96927	R1.5	25.0	25	54	121
EMI94928	EMI96928	R2.0	25.0	25	54	121
EMI94929	EMI96929	R2.5	25.0	25	54	121
EMI94930	EMI96930	R3.0	25.0	25	54	121
EMI94931	EMI96931	R4.0	25.0	25	54	121
EMI94932	EMI96932	R5.0	25.0	25	54	121

Mill Dia. Tolerance (in)	Shank Dia. Tolerance
0 ~ - 0.03	h5 * Shank Dia. ≥ Ø1/2 : h6

◎ : Excellent ○ : Good

ISO	P										M				K						
	Non-alloy steel					Low alloy steel					High alloyed steel, and tool steel				Stainless steel		Grey cast iron		Nodular cast iron		Malleable cast iron
VDI 3323	1	2	3	4	5	6	7	8	9	10	11	12	13	14	15	16	17	18	19	20	
HRc	13	25	28	32	32	10	29	32	38	15	35	15	23	10	10	26	3	25	19	21	
HB	125	190	250	270	300	180	275	300	350	200	325	200	240	180	180	260	160	250	130	230	
Recommend	○	○	○	○	○	○	○	○	○	○	○	◎	◎	◎	○	○	○	○	○	○	○

ISO	N					S										H						
	Aluminum-wrought alloy		Aluminum-cast, alloyed			Copper and Copper Alloys (Bronze / Brass)		Non Metallic Materials			Heat Resistant Super Alloys					Titanium Alloys		Hardened steel	Chilled Cast Iron	Hardened Cast Iron		
VDI 3323	21	22	23	24	25	26	27	28	29	30	31	32	33	34	35	36	37	38	39	40	41	
HRc						15	30	25	38	34							55	60	42	55		
HB	60	100	75	90	130	110	90	100			200	280	250	350	320	400 Rm	1050 Rm	550	630	400	550	
Recommend						○	○	○	○	○	○	○	○	○	○	◎	◎	○	○	○	○	○

HIGH PERFORMANCE SOLID CARBIDE END MILLS - TitaNox-Power HPC NEW SERIES
5-FLUTE STANDARD LENGTH PLAIN SHANK **EMI93**
FLAT SHANK **EMI95**

- ▶ New design enhances chip space in heavy cuts, while still maintaining rigidity in peel milling.
- ▶ Unequal index design for Chatter-Free cutting
- ▶ high performance milling of Stainless Steel, Titanium, and Heat-Resistant Super Alloys



Unit : mm

EDP No.		Mill Diameter	Shank Diameter	Length of Cut	Overall Length	Chamfer
PLAIN	FLAT	D1	D2	L1	L2	
EMI93060	EMI95060	6.0	6	13	57	0.20
EMI93080	EMI95080	8.0	8	19	63	0.20
EMI93100	EMI95100	10.0	10	22	72	0.30
EMI93120	EMI95120	12.0	12	26	83	0.35
EMI93160	EMI95160	16.0	16	36	92	0.40
EMI93200	EMI95200	20.0	20	44	104	0.50
EMI93250	EMI95250	25.0	25	54	121	0.50

Mill Dia. Tolerance (in)	Shank Dia. Tolerance
0 ~ - 0.03	h5 * Shank Dia. ≥Ø1/2 : h6

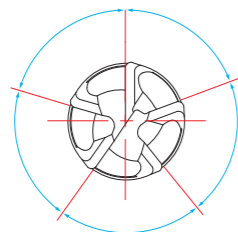

Unequal Index

Exclusively Designed Unique Geometry applied to Reduce Vibration and also to achieve Excellent surface finish

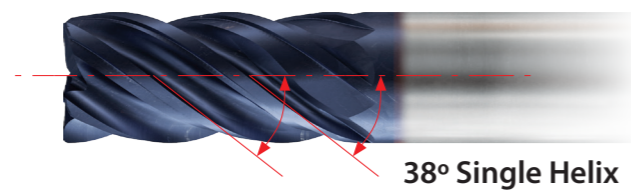

Core Design

YG-1's High Performance Core Geometries is designed for superior chip evacuation. It's excellent at Slotting & Heavy Profiling.

◎ : Excellent ○ : Good

ISO	P										M				K					
	Non-alloy steel					Low alloy steel					High alloyed steel, and tool steel		Stainless steel		Grey cast iron		Nodular cast iron		Malleable cast iron	
Material Description	1	2	3	4	5	6	7	8	9	10	11	12	13	14	15	16	17	18	19	20
VDI 3323	1	2	3	4	5	6	7	8	9	10	11	12	13	14	15	16	17	18	19	20
HRC	13	25	28	32	38	15	29	32	38	15	35	15	23	10	26	3	25	3	25	
HB	125	190	250	270	300	180	275	300	350	200	325	200	240	180	260	160	250	130	230	
Recommend	○	○	○	○	○	○	○	○	○	○	○	◎	◎	○	○	○	○	○	○	

ISO	N					S										H					
	Aluminum-wrought alloy		Aluminum-cast, alloyed			Copper and Copper Alloys (Bronze / Brass)			Non Metallic Materials		Heat Resistant Super Alloys					Titanium Alloys		Hardened steel	Chilled Cast Iron	Hardened Cast Iron	
Material Description	21	22	23	24	25	26	27	28	29	30	31	32	33	34	35	36	37	38	39	40	41
VDI 3323	21	22	23	24	25	26	27	28	29	30	31	32	33	34	35	36	37	38	39	40	41
HRC											15	30	25	38	34	55	60	55	60	42	55
HB	60	100	75	90	130	110	90	100			200	280	250	350	320	400 Rm	1050 Rm	550	630	400	550
Recommend											○	○	○	○	○	◎	◎				

RECOMMENDED CUTTING CONDITIONS

GMG40, GMG41 SERIES 4 FLUTES CORNER RADIUS - SIDE CUTTING

RPM = rev./min. FEED = mm/min.
Vc = m/min. fz = mm/tooth

ISO	VDI 3323	Material Description	Ae	Ap	Parameter	Diameter (Ø)								
						6.0	8.0	10.0	12.0	14.0	16.0	20.0	25.0	
P	1-4	Non-alloy steel	0.4D	1.0D	Vc	160	160	160	160	160	160	160	160	160
					fz	0.027	0.035	0.042	0.053	0.058	0.063	0.077	0.084	
					RPM	8488	6366	5093	4244	3638	3183	2546	2037	
	5	Low alloy steel	0.4D	1.0D	Vc	150	150	150	150	150	150	150	150	
					fz	0.025	0.035	0.042	0.049	0.056	0.063	0.070	0.084	
					RPM	7958	5968	4775	3979	3410	2984	2387	1910	
	6-7	Low alloy steel	0.4D	1.0D	Vc	160	160	160	160	160	160	160	160	
					fz	0.027	0.035	0.042	0.053	0.058	0.063	0.077	0.084	
					RPM	8488	6366	5093	4244	3638	3183	2546	2037	
	8	Low alloy steel	0.4D	1.0D	Vc	150	150	150	150	150	150	150	150	
					fz	0.025	0.035	0.042	0.049	0.056	0.063	0.070	0.084	
					RPM	7958	5968	4775	3979	3410	2984	2387	1910	
9	Low alloy steel	0.4D	1.0D	Vc	150	150	150	150	150	150	150	150		
				fz	0.027	0.035	0.046	0.053	0.060	0.067	0.077	0.084		
				RPM	7958	5968	4775	3979	3410	2984	2387	1910		
10-11.1	High alloyed steel, and tool steel	0.4D	1.0D	Vc	150	150	150	150	150	150	150	150		
				fz	0.027	0.035	0.046	0.053	0.060	0.067	0.077	0.084		
				RPM	7958	5968	4775	3979	3410	2984	2387	1910		
M	12-13	Stainless steel	0.4D	1.0D	Vc	155	155	155	155	155	155	155	155	
					fz	0.034	0.046	0.057	0.067	0.076	0.086	0.095	0.114	
					RPM	8223	6167	4934	4112	3524	3084	2467	1974	
	14.1	Stainless steel	0.4D	1.0D	Vc	105	105	105	105	105	105	105	105	
					fz	0.025	0.034	0.042	0.048	0.055	0.062	0.071	0.081	
					RPM	5570	4178	3342	2785	2387	2089	1671	1337	
	14.2	Stainless steel	0.4D	0.6D	Vc	44	44	44	44	44	44	44	44	
					fz	0.016	0.021	0.027	0.032	0.036	0.040	0.046	0.052	
					RPM	2334	1751	1401	1167	1000	875	700	560	
	K	15-20	Grey cast iron	0.4D	1.0D	Vc	175	175	175	175	175	175	175	175
						fz	0.021	0.028	0.035	0.042	0.048	0.053	0.060	0.070
						RPM	9284	6963	5570	4642	3979	3482	2785	2228
31-35		Heat Resistant Super Alloys	0.3D	0.6D	Vc	32	32	32	32	32	32	32	32	
					fz	0.020	0.026	0.032	0.038	0.044	0.048	0.055	0.065	
					RPM	1698	1273	1019	849	728	637	509	407	
36-37		Titanium Alloys	0.4D	1.0D	Vc	70	70	70	70	70	70	70	70	
					fz	0.034	0.048	0.057	0.067	0.076	0.086	0.095	0.114	
					RPM	3714	2785	2228	1857	1592	1393	1114	891	

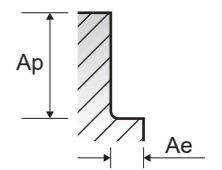

GMG40, GMG41 SERIES 4 FLUTES CORNER RADIUS - **SLOTTING**

RPM = rev./min. FEED = mm/min.
Vc = m/min. fz = mm/tooth

ISO	VDI 3323	Material Description	Ae	Ap	Parameter	Diameter (Ø)								
						6.0	8.0	10.0	12.0	14.0	16.0	20.0	25.0	
P	1-4	Non-alloy steel	1.0D	1.0D	Vc	125	125	125	125	125	125	125	125	
					fz	0.025	0.034	0.042	0.049	0.056	0.063	0.070	0.084	
					RPM	6631	4974	3979	3316	2842	2487	1989	1592	
					FEED	663	676	668	650	637	627	557	535	
	5	Non-alloy steel	1.0D	1.0D	Vc	120	120	120	120	120	120	120	120	
					fz	0.025	0.034	0.042	0.049	0.056	0.063	0.070	0.077	
					RPM	6366	4775	3820	3183	2728	2387	1910	1528	
					FEED	637	649	642	624	611	602	535	471	
	6-7	Low alloy steel	1.0D	1.0D	Vc	125	125	125	125	125	125	125	125	
					fz	0.025	0.034	0.042	0.049	0.056	0.063	0.070	0.084	
					RPM	6631	4974	3979	3316	2842	2487	1989	1592	
					FEED	663	676	668	650	637	627	557	535	
8-9	Low alloy steel	1.0D	1.0D	Vc	120	120	120	120	120	120	120	120		
				fz	0.025	0.034	0.042	0.049	0.056	0.063	0.070	0.077		
				RPM	6366	4775	3820	3183	2728	2387	1910	1528		
				FEED	637	649	642	624	611	602	535	471		
10-11.1	High alloyed steel, and tool steel	1.0D	1.0D	Vc	120	120	120	120	120	120	120	120		
				fz	0.027	0.035	0.042	0.053	0.058	0.063	0.077	0.084		
				RPM	6366	4775	3820	3183	2728	2387	1910	1528		
				FEED	688	668	642	675	633	602	588	513		
M	12-13	Stainless steel	1.0D	1.0D	Vc	125	125	125	125	125	125	125	125	
					fz	0.034	0.046	0.057	0.067	0.074	0.081	0.095	0.105	
					RPM	6631	4974	3979	3316	2842	2487	1989	1592	
	14.1	Stainless steel	1.0D	1.0D	Vc	85	85	85	85	85	85	85	85	
					fz	0.025	0.034	0.042	0.048	0.055	0.062	0.071	0.081	
					RPM	4509	3382	2706	2255	1933	1691	1353	1082	
	14.2	Stainless steel	1.0D	0.5D	Vc	36	36	36	36	36	36	36	36	
					fz	0.016	0.021	0.027	0.032	0.036	0.040	0.046	0.052	
					RPM	1910	1432	1146	955	819	716	573	458	
	K	15-20	Grey cast iron	1.0D	1.0D	Vc	140	140	140	140	140	140	140	140
						fz	0.021	0.028	0.035	0.042	0.048	0.053	0.060	0.067
						RPM	7427	5570	4456	3714	3183	2785	2228	1783
S		31-35	Heat Resistant Super Alloys	1.0D	0.4D	Vc	25	25	25	25	25	25	25	25
						fz	0.018	0.024	0.030	0.036	0.040	0.044	0.050	0.055
						RPM	1326	995	796	663	568	497	398	318
		36-37	Titanium Alloys	1.0D	1.0D	Vc	55	55	55	55	55	55	55	55
						fz	0.034	0.046	0.057	0.067	0.076	0.086	0.095	0.105
						RPM	2918	2188	1751	1459	1251	1094	875	700

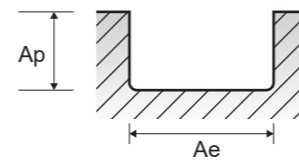

GMG28 GMG30 GMG29 GMG31 5 FLUTE CORNER RADIUS - **SIDE CUTTING**

RPM = rev./min. FEED = mm/min.
Vc = m/min. fz = mm/tooth

ISO	VDI 3323	Material Description	Ae	Ap	Parameter	Diameter (Ø)										
						6.0	8.0	10.0	12.0	14.0	16.0	18.0	20.0	25.0		
P	1-4	Non-alloy steel	0.3D	1.5D(*)	Vc	144	144	144	144	144	144	144	144	144	144	
					fz	0.034	0.038	0.050	0.063	0.069	0.076	0.083	0.089	0.101		
					RPM	7639	5730	4584	3820	3274	2865	2546	2292	1833		
					FEED	1299	1089	1146	1203	1130	1089	1057	1020	926		
	5	Non-alloy steel	0.3D	1.5D(*)	Vc	101	101	101	101	101	101	101	101	101	101	
					fz	0.034	0.038	0.050	0.063	0.069	0.076	0.083	0.089	0.101		
					RPM	5358	4019	3215	2679	2296	2009	1786	1607	1286		
					FEED	911	764	804	844	792	764	741	715	649		
	6-7	Low alloy steel	0.3D	1.5D(*)	Vc	144	144	144	144	144	144	144	144	144	144	
					fz	0.034	0.038	0.050	0.063	0.069	0.076	0.083	0.089	0.101		
					RPM	7639	5730	4584	3820	3274	2865	2546	2292	1833		
					FEED	1299	1089	1146	1203	1130	1089	1057	1020	926		
8-9	Low alloy steel	0.3D	1.5D(*)	Vc	101	101	101	101	101	101	101	101	101	101		
				fz	0.034	0.038	0.050	0.063	0.069	0.076	0.083	0.089	0.101			
				RPM	5358	4019	3215	2679	2296	2009	1786	1607	1286			
				FEED	911	764	804	844	792	764	741	715	649			
10-11.1	High alloyed steel, and tool steel	0.3D	1.5D(*)	Vc	60	60	60	60	60	60	60	60	60	60		
				fz	0.024	0.027	0.035	0.044	0.049	0.054	0.058	0.062	0.071			
				RPM	3183	2387	1910	1592	1364	1194	1061	955	764			
				FEED	382	322	334	350	334	322	308	296	271			
M	12-13	Stainless steel	0.3D	1.5D(*)	Vc	117	117	117	117	117	117	117	117	117		
					fz	0.024	0.025	0.030	0.046	0.051	0.054	0.057	0.061	0.071		
					RPM	6207	4655	3724	3104	2660	2328	2069	1862	1490		
	14.1	Stainless steel	0.3D	1.5D(*)	Vc	82	82	82	82	82	82	82	82	82		
					fz	0.030	0.032	0.038	0.063	0.065	0.069	0.070	0.076	0.088		
					RPM	4350	3263	2610	2175	1864	1631	1450	1305	1044		
	14.2	Stainless steel	0.3D	1.5D(*)	Vc	59	59	59	59	59	59	59	59	59		
					fz	0.030	0.032	0.038	0.063	0.065	0.069	0.070	0.076	0.088		
					RPM	3130	2348	1878	1565	1341	1174	1043	939	751		
	K	15-20	Grey cast iron	0.3D	1.5D(*)	Vc	106	106	106	106	106	106	106	106	106	
						fz	0.043	0.048	0.063	0.079	0.087	0.096	0.103	0.111	0.126	
						RPM	5623	4218	3374	2812	2410	2109	1874	1687	1350	
S		31-35	Heat Resistant Super Alloys	0.1D	1.5D	Vc	31	31	31	31	31	31	31	31	31	
						fz	0.021	0.022	0.027	0.044	0.046	0.048	0.049	0.053	0.062	
						RPM	1645	1233	987	822	705	617	548	493	395	
		36-37	Titanium Alloys	0.3D	1.5D(*)	Vc	69	69	69	69	69	69	69	69	69	
						fz	0.027	0.029	0.034	0.057	0.059	0.062	0.063	0.069	0.079	
						RPM	3661	2745	2196	1830	1569	1373	1220	1098	879	

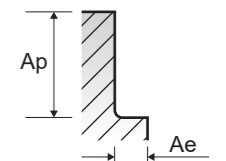

* Maximum recommended depth shown.
 * Finish cuts typically require reduced feed rates and/or higher spindle speed, with radial width of 2% x D1 or less.
 * Reduce speed and feed recommendations for materials harder than listed.
 * Above recommendations are based on ideal conditions.
 Adjust parameters accordingly for smaller taper machining centers or less rigid conditions.

**GMG24 GMG26
GMG25 GMG27** 5 FLUTE - SIDE CUTTING

RPM = rev./min. FEED = mm/min.
Vc = m/min. fz = mm/tooth

ISO	VDI 3323	Material Description	Ae	Ap	Parameter	Diameter (∅)									
						6.0	8.0	10.0	12.0	14.0	16.0	18.0	20.0	25.0	
P	1-4 5	Non-alloy steel	0.3D	1.5D(*)	Vc	144	144	144	144	144	144	144	144	144	144
					fz	0.034	0.038	0.050	0.063	0.069	0.076	0.083	0.089	0.101	0.101
					RPM	7639	5730	4584	3820	3274	2865	2546	2292	1833	1833
					FEED	1299	1089	1146	1203	1130	1089	1057	1020	926	926
					Vc	101	101	101	101	101	101	101	101	101	101
					fz	0.034	0.038	0.050	0.063	0.069	0.076	0.083	0.089	0.101	0.101
	6-7	Low alloy steel	0.3D	1.5D(*)	Vc	144	144	144	144	144	144	144	144	144	
					fz	0.034	0.038	0.050	0.063	0.069	0.076	0.083	0.089	0.101	
					RPM	7639	5730	4584	3820	3274	2865	2546	2292	1833	
					FEED	1299	1089	1146	1203	1130	1089	1057	1020	926	
					Vc	101	101	101	101	101	101	101	101	101	
					fz	0.034	0.038	0.050	0.063	0.069	0.076	0.083	0.089	0.101	
	8-9	High alloyed steel, and tool steel	0.3D	1.5D(*)	Vc	101	101	101	101	101	101	101	101	101	
					fz	0.034	0.038	0.050	0.063	0.069	0.076	0.083	0.089	0.101	
					RPM	5358	4019	3215	2679	2296	2009	1786	1607	1286	
FEED					911	764	804	844	792	764	741	715	649		
Vc					60	60	60	60	60	60	60	60	60		
fz					0.024	0.027	0.035	0.044	0.049	0.054	0.058	0.062	0.071		
M	12-13	Stainless steel	0.3D	1.5D(*)	Vc	117	117	117	117	117	117	117	117	117	
					fz	0.024	0.025	0.030	0.046	0.051	0.054	0.057	0.061	0.071	
					RPM	6207	4655	3724	3104	2660	2328	2069	1862	1490	
					FEED	745	582	559	714	678	628	590	568	529	
					Vc	82	82	82	82	82	82	82	82	82	
					fz	0.030	0.032	0.038	0.063	0.065	0.069	0.070	0.076	0.088	
	14.1	Stainless steel	0.3D	1.5D(*)	Vc	4350	3263	2610	2175	1864	1631	1450	1305	1044	
					fz	653	522	496	685	606	563	508	496	459	
					RPM	59	59	59	59	59	59	59	59	59	
					FEED	0.030	0.032	0.038	0.063	0.065	0.069	0.070	0.076	0.088	
					Vc	3130	2348	1878	1565	1341	1174	1043	939	751	
					fz	470	376	357	493	436	405	365	357	331	
	14.2	Stainless steel	0.3D	1.5D(*)	Vc	106	106	106	106	106	106	106	106	106	
					fz	0.043	0.048	0.063	0.079	0.087	0.096	0.103	0.111	0.126	
					RPM	5623	4218	3374	2812	2410	2109	1874	1687	1350	
FEED					1209	1012	1063	1111	1048	1012	965	936	850		
Vc					31	31	31	31	31	31	31	31	31		
fz					0.021	0.022	0.027	0.044	0.046	0.048	0.049	0.053	0.062		
K	15-20	Grey cast iron	0.3D	1.5D(*)	Vc	31	31	31	31	31	31	31	31	31	
					fz	0.021	0.022	0.027	0.044	0.046	0.048	0.049	0.053	0.062	
					RPM	1645	1233	987	822	705	617	548	493	395	
					FEED	173	136	133	181	162	148	134	131	122	
					Vc	69	69	69	69	69	69	69	69	69	
					fz	0.027	0.029	0.034	0.057	0.059	0.062	0.063	0.069	0.079	
	31-35	Heat Resistant Super Alloys	0.1D	1.5D	Vc	69	69	69	69	69	69	69	69	69	
					fz	0.027	0.029	0.034	0.057	0.059	0.062	0.063	0.069	0.079	
					RPM	3661	2745	2196	1830	1569	1373	1220	1098	879	
					FEED	494	398	373	522	463	426	384	379	347	
					Vc	69	69	69	69	69	69	69	69	69	
					fz	0.027	0.029	0.034	0.057	0.059	0.062	0.063	0.069	0.079	
	36-37	Titanium Alloys	0.3D	1.5D(*)	Vc	69	69	69	69	69	69	69	69	69	
					fz	0.027	0.029	0.034	0.057	0.059	0.062	0.063	0.069	0.079	
					RPM	3661	2745	2196	1830	1569	1373	1220	1098	879	
FEED					494	398	373	522	463	426	384	379	347		
Vc					69	69	69	69	69	69	69	69	69		
fz					0.027	0.029	0.034	0.057	0.059	0.062	0.063	0.069	0.079		

- * Maximum recommended depth shown.
- * Finish cuts typically require reduced feed rates and/or higher spindle speed, with radial width of 2% x D1 or less.
- * Reduce speed and feed recommendations for materials harder than listed.
- * Above recommendations are based on ideal conditions.
- Adjust parameters accordingly for smaller taper machining centers or less rigid conditions.

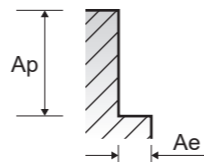

EHE54, EHE55 SERIES 5 FLUTES ROUGHING - SIDE CUTTING

ISO	VDI 3323	Material Description	Ae	Ap	Parameter	Diameter (∅)								
						6.0	8.0	10.0	12.0	14.0	16.0	20.0	25.0	
M	12-13	Stainless steel	~∅10/0.15D ~∅16/0.10D ~∅25/0.05D	1.5D	Vc	80	80	80	80	80	80	80	80	80
					fz	0.025	0.034	0.041	0.051	0.057	0.063	0.081	0.091	
					RPM	4244	3183	2546	2122	1819	1592	1273	1019	
					FEED	531	541	522	541	518	501	516	463	
S	31-35	Heat Resistant Super Alloys	~∅10/0.15D ~∅16/0.10D ~∅25/0.05D	1.0D	Vc	40	40	40	40	40	40	40	40	40
					fz	0.020	0.025	0.037	0.040	0.046	0.052	0.061	0.068	
					RPM	2122	1592	1273	1061	909	796	637	509	
	36-37	Titanium Alloys		Vc	65	65	65	65	65	65	65	65	65	
				fz	0.022	0.031	0.038	0.046	0.052	0.058	0.074	0.084		
				RPM	3448	2586	2069	1724	1478	1293	1035	828		
FEED	379	401	393	397	384	375	383	348						

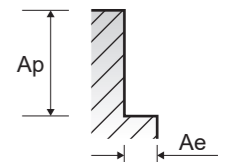

**EMI94 EMI93
EMI96 EMI95** 5 FLUTES CORNER RADIUS (TitaNox-Power HPC) - SIDE CUTTING (Heavy Side Cutting)

RPM = rev./min. FEED = mm/min.
Vc = m/min. fz = mm/tooth

ISO	VDI 3323	Material Description	Ae	Ap	Parameter	Diameter (∅)								
						6.0	8.0	10.0	12.0	16.0	20.0	25.0		
P	1~5	Non-alloy steel	0.5D	1.5D	Vc	152	152	152	152	152	152	152	152	152
					fz	0.038	0.046	0.059	0.074	0.095	0.115	0.123		
					RPM	8064	6048	4838	4032	3024	2419	1935		
	6~8	Low alloy steel	0.5D	1.5D	Vc	152	152	152	152	152	152	152	152	
					fz	0.038	0.046	0.059	0.074	0.095	0.115	0.123		
					RPM	8064	6048	4838	4032	3024	2419	1935		
	9	High alloyed steel, and tool steel	0.5D	1.5D	Vc	122	122	122	122	122	122	122	122	
					fz	0.029	0.036	0.045	0.058	0.072	0.088	0.095		
					RPM	6472	4854	3883	3236	2427	1942	1553		
	10	High alloyed steel, and tool steel	0.5D	1.5D	Vc	137	137	137	137	137	137	137	137	
					fz	0.038	0.046	0.059	0.074	0.095	0.115	0.123		
					RPM	7268	5451	4361	3634	2726	2180	1744		
	11.1	High alloyed steel, and tool steel	0.5D	1.5D	Vc	122	122	122	122	122	122	122	122	
					fz	0.029	0.036	0.045	0.058	0.072	0.088	0.095		
					RPM	6472	4854	3883	3236	2427	1942	1553		
M	12	Stainless steel	0.5D	1.5D	Vc	76	76	76	76	76	76	76	76	
					fz	0.024	0.031	0.040	0.050	0.061	0.075	0.080		
					RPM	4032	3024	2419	2016	1512	1210	968		
	14.1	Stainless steel	0.5D	1.5D	Vc	484	469	484	504	461	454	387		
					fz	91	91	91	91	91	91	91		
					RPM	0.031	0.036	0.048	0.062	0.072	0.083	0.090		
	14.2	Stainless steel	0.5D	1.5D	Vc	4828	3621	2897	2414	1810	1448	1159		
					fz	748	652	695	748	652	601	522		
					RPM	61	61	61	61	61	61	61		
	K	15~20	Grey cast iron	0.5D	1.5D	Vc	61	61	61	61	61	61	61	
						fz	0.024	0.028	0.037	0.050	0.056	0.067	0.073	
						RPM	3236	2427	1942	1618	1214	971	777	
		33	Heat Resistant Super Alloys	0.2D	1.5D	Vc	388	340	359	405	340	325	284	
						fz	113	113	113	113	113	113	113	
						RPM	0.034	0.041	0.051	0.062	0.082	0.099	0.105	
S	37	Titanium Alloys	0.5D	1.5D	Vc	5995	4496	3597	2997	2248	1798	1439		
					fz	1019	922	917	929	922	890	755		
					RPM	27	27	27	27	27	27	27		
	36-37	Titanium Alloys	0.5D	1.5D	Vc	27	27	27	27	27	27	27		
					fz	0.024	0.031	0.037	0.046	0.054	0.061	0.068		
					RPM	1432	1074	859	716	537	430	344		
FEED	172	166	159	165	145	131	117							

EMI94 EMI93
EMI96 EMI95 5 FLUTES CORNER RADIUS (TitaNox-Power HPC)
- SIDE CUTTING (Peel Milling)

RPM = rev./min. FEED = mm/min.
Vc = m/min. fz = mm/tooth

ISO	VDI 3323	Material Description	Ae	Ap	Parameter	Diameter (Ø)							
						6.0	8.0	10.0	12.0	16.0	20.0	25.0	
P	1~5	Non-alloy steel	0.08D	2.0D	Vc	198	198	198	198	198	198	198	
					fz	0.053	0.067	0.083	0.103	0.131	0.160	0.170	
					RPM	10504	7878	6303	5252	3939	3151	2521	
	6~8	Low alloy steel	0.08D	2.0D	Vc	198	198	198	198	198	198	198	
					fz	0.053	0.067	0.083	0.103	0.131	0.160	0.170	
					RPM	10504	7878	6303	5252	3939	3151	2521	
	9	High alloyed steel, and tool steel	0.08D	2.0D	Vc	198	198	198	198	198	198	198	
					fz	0.041	0.051	0.064	0.079	0.102	0.123	0.133	
					RPM	10504	7878	6303	5252	3939	3151	2521	
	10	High alloyed steel, and tool steel	0.08D	2.0D	Vc	177	177	177	177	177	177	177	
					fz	0.053	0.067	0.083	0.103	0.131	0.160	0.170	
					RPM	9390	7043	5634	4695	3521	2817	2254	
11.1	High alloyed steel, and tool steel	0.08D	2.0D	Vc	168	168	168	168	168	168	168		
				fz	0.041	0.051	0.064	0.079	0.102	0.123	0.133		
				RPM	8913	6685	5348	4456	3342	2674	2139		
M	12	Stainless steel	0.06D	2.0D	Vc	107	107	107	107	107	107	107	
					fz	0.036	0.041	0.056	0.070	0.087	0.104	0.113	
					RPM	5677	4257	3406	2838	2129	1703	1362	
	14.1	Stainless steel	0.06D	2.0D	Vc	130	130	130	130	130	130	130	
					fz	0.043	0.049	0.067	0.086	0.100	0.117	0.128	
					RPM	6897	5173	4138	3448	2586	2069	1655	
	14.2	Stainless steel	0.06D	2.0D	Vc	91	91	91	91	91	91	91	
					fz	0.034	0.038	0.053	0.070	0.079	0.093	0.103	
					RPM	4828	3621	2897	2414	1810	1448	1159	
	K	15~20	Grey cast iron	0.07D	2.0D	Vc	168	168	168	168	168	168	168
						fz	0.048	0.056	0.072	0.089	0.115	0.139	0.148
						RPM	8913	6685	5348	4456	3342	2674	2139
33		Heat Resistant Super Alloys	0.04D	2.0D	Vc	37	37	37	37	37	37	37	
					fz	0.024	0.031	0.037	0.046	0.054	0.061	0.068	
					RPM	1963	1472	1178	981	736	589	471	
37		Titanium Alloys	0.05D	2.0D	Vc	91	91	91	91	91	91	91	
					fz	0.024	0.031	0.037	0.046	0.054	0.061	0.068	
					RPM	4828	3621	2897	2414	1810	1448	1159	

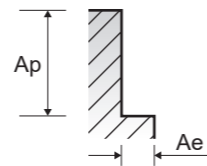

EMI94 EMI93
EMI96 EMI95 5 FLUTES CORNER RADIUS (TitaNox-Power HPC)
- SLOTTING

RPM = rev./min. FEED = mm/min.
Vc = m/min. fz = mm/tooth

ISO	VDI 3323	Material Description	Ae	Ap	Parameter	Diameter (Ø)							
						6.0	8.0	10.0	12.0	16.0	20.0	25.0	
P	1~5	Non-alloy steel	1.0D	1.0D	Vc	84	84	84	84	84	84	84	
					fz	0.031	0.038	0.048	0.058	0.074	0.091	0.098	
					RPM	4456	3342	2674	2228	1671	1337	1070	
	6~8	Low alloy steel	1.0D	1.0D	Vc	84	84	84	84	84	84	84	
					fz	0.031	0.038	0.048	0.058	0.074	0.091	0.098	
					RPM	4456	3342	2674	2228	1671	1337	1070	
	9	High alloyed steel, and tool steel	1.0D	1.0D	Vc	84	84	84	84	84	84	84	
					fz	0.024	0.028	0.037	0.046	0.059	0.069	0.075	
					RPM	4456	3342	2674	2228	1671	1337	1070	
	10	High alloyed steel, and tool steel	1.0D	0.75D	Vc	70	70	70	70	70	70	70	
					fz	0.031	0.038	0.048	0.058	0.074	0.091	0.098	
					RPM	3714	2785	2228	1857	1393	1114	891	
11.1	High alloyed steel, and tool steel	1.0D	0.75D	Vc	76	76	76	76	76	76	76		
				fz	0.024	0.028	0.037	0.046	0.059	0.069	0.075		
				RPM	4032	3024	2419	2016	1512	1210	968		
M	12	Stainless steel	1.0D	0.5D	Vc	69	69	69	69	69	69	69	
					fz	0.019	0.023	0.032	0.041	0.049	0.059	0.065	
					RPM	3661	2745	2196	1830	1373	1098	879	
	14.1	Stainless steel	1.0D	0.5D	Vc	76	76	76	76	76	76	76	
					fz	0.024	0.028	0.037	0.050	0.059	0.067	0.073	
					RPM	4032	3024	2419	2016	1512	1210	968	
	14.2	Stainless steel	1.0D	0.5D	Vc	61	61	61	61	61	61	61	
					fz	0.019	0.023	0.029	0.041	0.046	0.053	0.058	
					RPM	3236	2427	1942	1618	1214	971	777	
	K	15~20	Grey cast iron	1.0D	1.0D	Vc	79	79	79	79	79	79	79
						fz	0.026	0.033	0.040	0.050	0.067	0.080	0.085
						RPM	4191	3143	2515	2096	1572	1257	1006
33		Heat Resistant Super Alloys	0.2D	1.5D	Vc	20	20	20	20	20	20	20	
					fz	0.019	0.026	0.029	0.036	0.044	0.051	0.053	
					RPM	1061	796	637	531	398	318	255	
37		Titanium Alloys	0.5D	1.5D	Vc	49	49	49	49	49	49	49	
					fz	0.019	0.026	0.029	0.036	0.044	0.051	0.053	
					RPM	2600	1950	1560	1300	975	780	624	

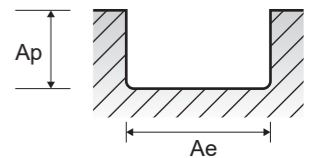



INDUSTRY-LEADING SOLID CARBIDE END MILLS

HIGH-PERFORMANCE MACHINING MADE EASY

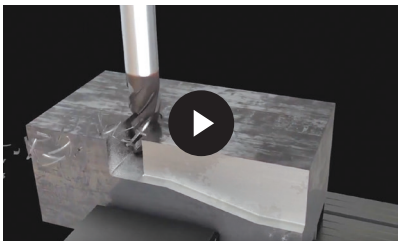

Scan this QR code to
see our TitaNox-Power tools at work.

YG YG-1 CO., LTD.

HEAD OFFICE

13-40, Songdogwahak-ro 16beon-gil,
Yeonsu-gu, Incheon 21984, South Korea

Note YG-1 Global head office is relocating from December 2020 to a new address as above;

Phone: +82-32-526-0909

www.yg1.kr

E-mail: yg1@yg1.kr

Note The information is provided for reference only. Tool specifications are subject to change without prior notice.
Although we endeavor to supply accurate and timely information, there can be no guarantee to cover every particular application.
YG-1 or publishers are not liable for any damage for use of the information.



Search 'YG-1' on social media outlets

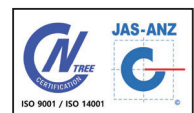

YG1YEHPC190325001